

YAMAHA

PARTS CATALOGUE

YZ125LC'92 (4DB1)

EUROPE

YZ125D (4DB2)

U.S.A., CANADA, OTHERS, S.AFRICA

YZ125 (4DB3)

JAPAN

YZ125D (4DB4)

OCEANIA

124DB-100E1

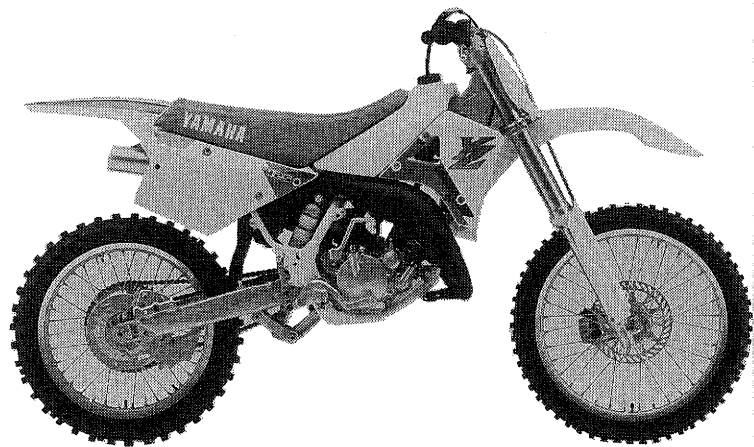



FOREWORD

This Parts Catalogue is related to the parts in use for the Yamaha YZ125LC'92(4DB1)/YZ125D(4DB2)/YZ125(4DB3)/YZ125D(4DB4). When you are ordering replacement parts for the YZ125LC'92(4DB1)/YZ125D(4DB2)/YZ125(4DB3)/YZ125D(4DB4), refer to this Parts Catalogue and quote both part numbers and part names correctly.

1. Modifications or additions which have been made after issue of the Parts Catalogue will be announced in the Yamaha Parts News.

It is advisable that according to the Yamaha Parts News you make necessary corrections to the Parts Catalogue on hand to keep it up-to-date.

2. Abbreviations

The following abbreviations are used in this Parts Catalogue.

- U.R. Use size (thickness) and/or number as required.
- U.N. Use as many as you need.
- A.P. Alternate Parts
- L.M. Local Made
- F# Frame No. (Applicable machine No.)

3. The parts marked with (+) in the parts number column of this Catalogue are not supplied with by Yamaha, those have to be found locally.
4. Parts, which are to be supplied in the form of assemblies, are listed with an indentation of one letter's space, and a dot (.) is put against the name of each part.

EXAMPLE CARBURETOR ASS'Y
 . JET, pilot
 . NOZZLE, main

5. Indication of No. of constituent parts for assembly

The numeral appearing to the right of each constituent part under the description indicates the quantity of such parts for each individual assembly unit.

EXAMPLE

Part No.	Description	Q'ty	Remarks
2F5-83310-60	FRONT FLASHER LIGHT ASS'Y	2	
115-83311-60	. BULB (6V-18W)	1	
1M1-83309-60	. REFLECTOR	1	

6. Initial Serial No. and Color Code

4DB1	(A) Frame Serial No.	4DB-000101 and following
	(B) Engine Serial No.	4DB-000101 and following
4DB2	(A) Frame Serial No.	4DB-007101 and following
	(B) Engine Serial No.	4DB-007101 and following
4DB3	(A) Frame Serial No.	4DB-012101 and following
	(B) Engine Serial No.	4DB
4DB4	(A) Frame Serial No.	4DB-014101 and following
	(B) Engine Serial No.	4DB-014101 and following

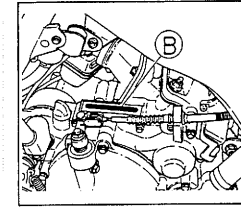
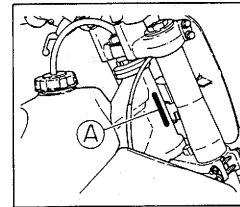

Color Code	Color Name	Abbreviate
0206	PURPLISH WHITE SOLID 1	PWS1

7. Applicable colors of graphics are represented in the "Remarks" column by the letter(s) appropriately picked out of the full word(s) showing such colors.

EXAMPLE

Part No.	Description	Q'ty	Remarks
2N4-24110-00-X5	FUEL TANK COMP.	1	MAXIM RED
3J1-24240-10	. GRAPHIC, fuel tank set	1	for MXR

CONTENTS

ENGINE

Cylinder Head	B2 ~ B3
Governor	B4
Crankshaft, Piston	B5
Water Pump	B6
Radiator, Hose	B7
Intake	B8
Carburetor	B9 ~ B10
Exhaust	B11
Crankcase	B12
Crankcase Cover 1	B13
Starter	B14
Clutch	B15 ~ C2
Transmission	C3 ~ C4
Shift Cam, Fork	C5
Shift Shaft	C6

CHASSIS

Frame	C7 ~ C8
Fender	C9
Side Cover	C10 ~ C11
Rear Arm	C12 ~ C13
Rear Suspension	C14
Steering	C15
Front Fork	D2 ~ D4
Fuel Tank	D5
Seat	D6
Front Wheel	D7
Front Brake Caliper	D8
Rear Wheel	D9 ~ D10

Rear Brake Caliper	D11
Steering Handle, Cable	D12
Front Master Cylinder	D13
Stand, Footrest	D14
Rear Master Cylinder	D15
Generator	E2
Handle Switch, Lever	E3
Electrical 1	E4

ALTERNATE PARTS

Alternate (Chassis)	E5
---------------------------	----

REPAIR KIT

Repair Kit	E6
------------------	----

INDEX

Numerical Index	M1 ~ M3
-----------------------	---------

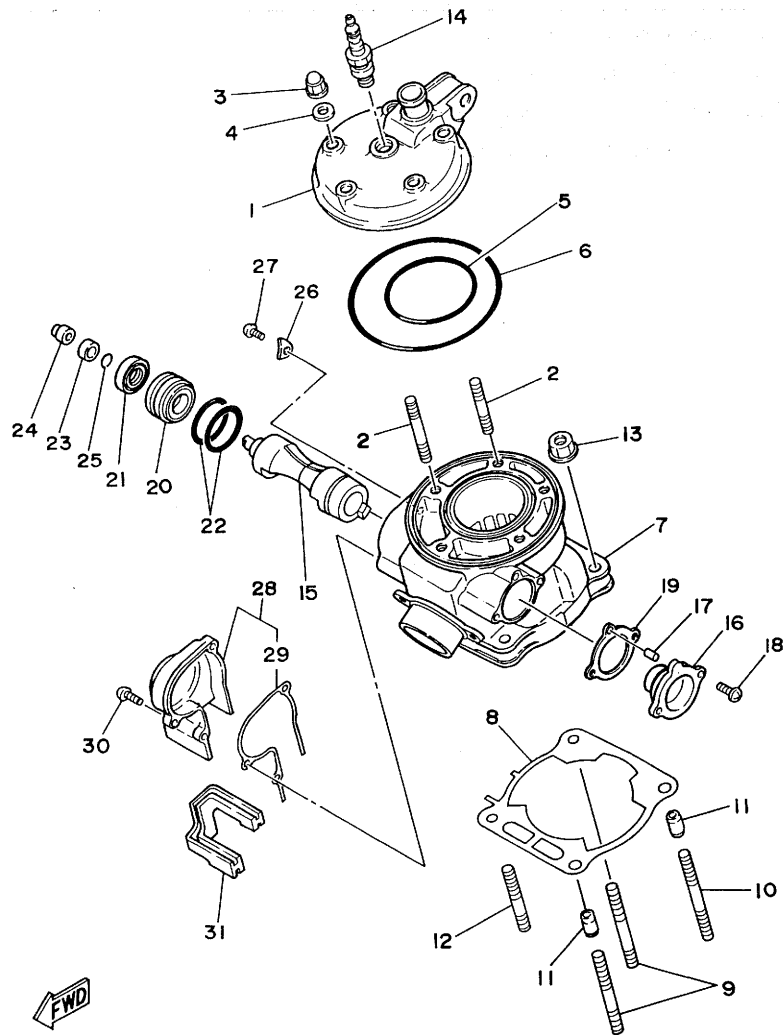

FIG. 1 CYLINDER HEAD

REF. NO.	PART NO.	DESCRIPTION	Q'TY	REMARKS
1	4DB-11111-00	HEAD, cylinder 1	1	
2	90116-08394	BOLT, stud	5	
3	90176-08026	NUT, crown	5	
4	90201-08087	WASHER, plate	5	
5	93210-65721	O-RING	1	
6	93211-07720	O-RING	1	
7	4DB-11311-00	CYLINDER 1	1	
8	1LX-11351-10	GASKET, cylinder	1	
9	90116-08388	BOLT, stud	2	
10	90116-08302	BOLT, stud	1	
11	99510-10114	PIN, dowel	2	
12	90116-08533	BOLT, stud	1	
13	90179-08491	NUT	4	
14	94702-00324	PLUG, spark (NGK BR9EG)	1	UR
	94709-00324	PLUG, spark	1	UR FOR JAPAN
15	4DB-1131A-00	VALVE 1	1	
16	4DB-W1132-00	HOLDER 1	1	
17	93604-08071	PIN, dowel	1	
18	98501-05012	SCREW, pan head	2	
19	4DB-1131N-00	GASKET, holder	1	
20	4DB-1131F-00	HOLDER 2	1	
21	93104-16074	OIL SEAL	1	
22	93210-27672	O-RING	2	
23	90387-102W0	COLLAR	1	
24	3JE-11937-00	BOSS, lever	1	
25	93210-09192	O-RING	1	
26	47X-11915-00	PLATE, thrust 1	1	
27	98506-05008	SCREW, pan head	1	

4DB2100-2010

B2

FIG. 1 CYLINDER HEAD

REF. NO.	PART NO.	DESCRIPTION	Q'TY	REMARKS
28	4DB-11992-00	HOUSING 2	1	
29	4DB-11993-00	.GASKET	1	
30	98580-05014	SCREW, pan head	3	
31	1LX-11995-01	SEAL, housing	1	

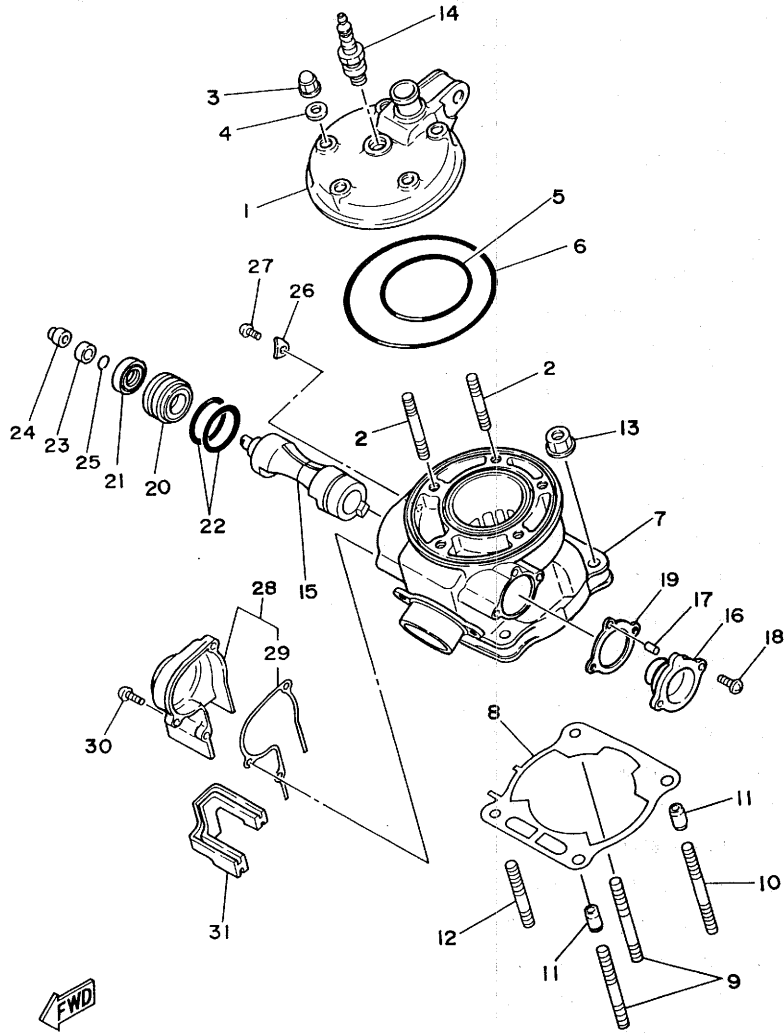

4DB 2100-2010

B3

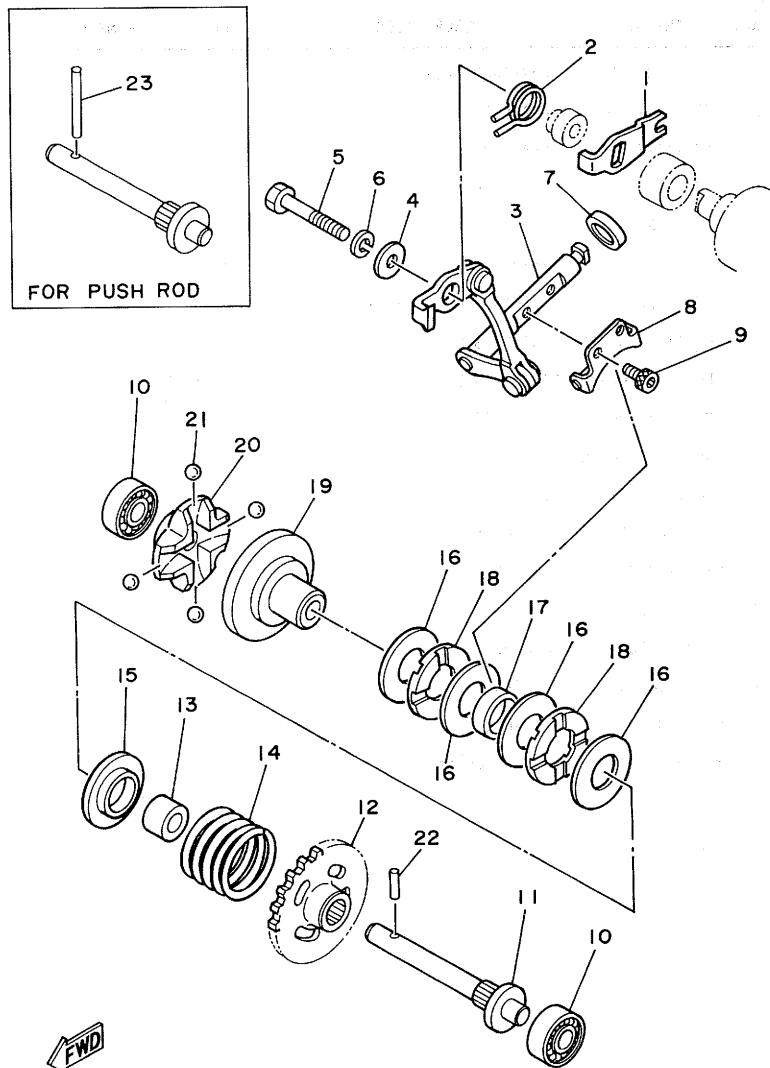

3SR2100-0021

FIG. 2 GOVERNOR

REF. NO.	PART NO.	DESCRIPTION	Q'TY	REMARKS
1	3JE-11931-00	LEVER	1	
2	90508-14783	SPRING, torsion	1	
3	3SR-11990-00	PUSH ROD ASSY	1	
4	90201-057H5	WASHER, plate	1	
5	97021-05030	BOLT	1	
6	92990-05100	WASHER, spring	1	
7	93104-08040	OIL SEAL	1	
8	5X4-11922-00	FORK, governor	1	
9	91316-04006	BOLT	2	
10	93300-60814	BEARING (608M4ML01)	2	NMB
11	5X4-11921-02	SHAFT, governor	1	
12	3JD-11953-00	GEAR, governor	1	
13	90560-08213	SPACER	1	
14	90501-240E7	SPRING, compression	1	
15	5X4-11952-00	PLATE	1	
16	90201-154E9	WASHER, plate	4	
17	90387-152F2	COLLAR	1	
18	93340-21505	BEARING, thrust	2	
19	5X5-11912-01	RETAINER, weight	1	
20	5X5-11911-01	RETAINER	1	
21	93521-64032	BALL	4	
22	93603-14179	PIN, dowel	1	
23	93604-29184	PIN, dowel	1	AP FOR PUSH ROD

B4

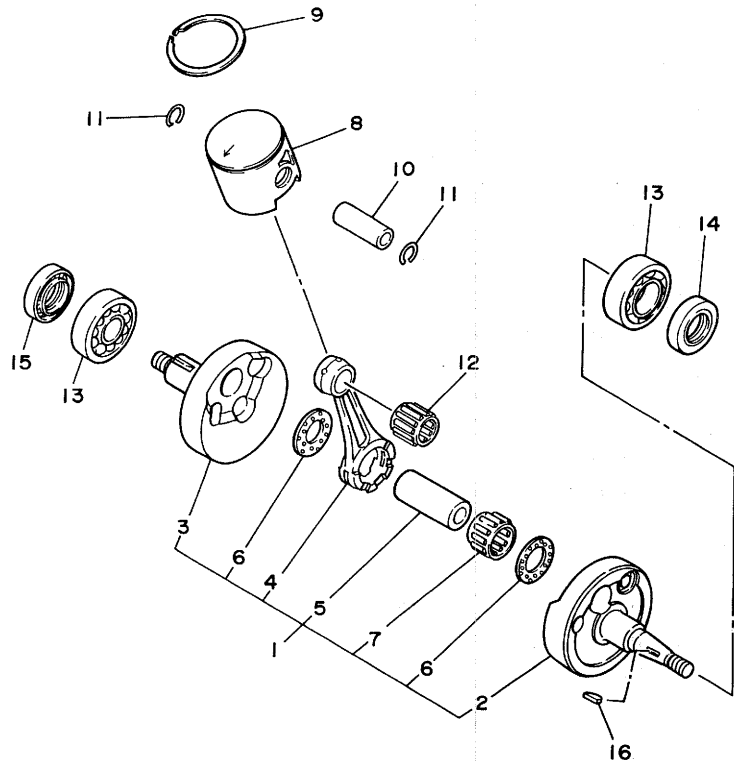

FIG. 3 CRANKSHAFT. PISTON

REF. NO.	PART NO.	DESCRIPTION	Q'TY	REMARKS
1	3XJ-11400-00	CRANKSHAFT ASSY	1	
2	3SR-11412-00	.CRANK 1	1	
3	3XJ-11422-00	.CRANK 2	1	
4	2HG-11651-00	.ROD, connecting	1	
5	3JD-11681-00	.PIN, crank 1	1	
6	90209-22257	.WASHER	2	
7	93310-522M4	.BEARING, cylindrical	1	
8	4DB-11631-00-A0	PISTON (STD)	1	UR RED
	4DB-11631-00-B0	PISTON (STD)	1	UR ORANGE
	4DB-11631-00-C0	PISTON (STD)	1	UR GREEN
	4DB-11631-00-D0	PISTON (STD)	1	UR PURPLE
9	5X4-11611-01	RING, piston	1	
10	137-11633-00	PIN, piston	1	
11	93450-17129	CIRCLIP	2	
12	93310-216L2	BEARING, cylindrical	1	
13	93306-37204	BEARING (63/22SH2-9TC4)	2	KOYO
14	93102-22363	OIL SEAL	1	
15	93103-32171	OIL SEAL	1	
16	90280-03017	KEY, woodruff	1	



3XJ1100-1030

B5

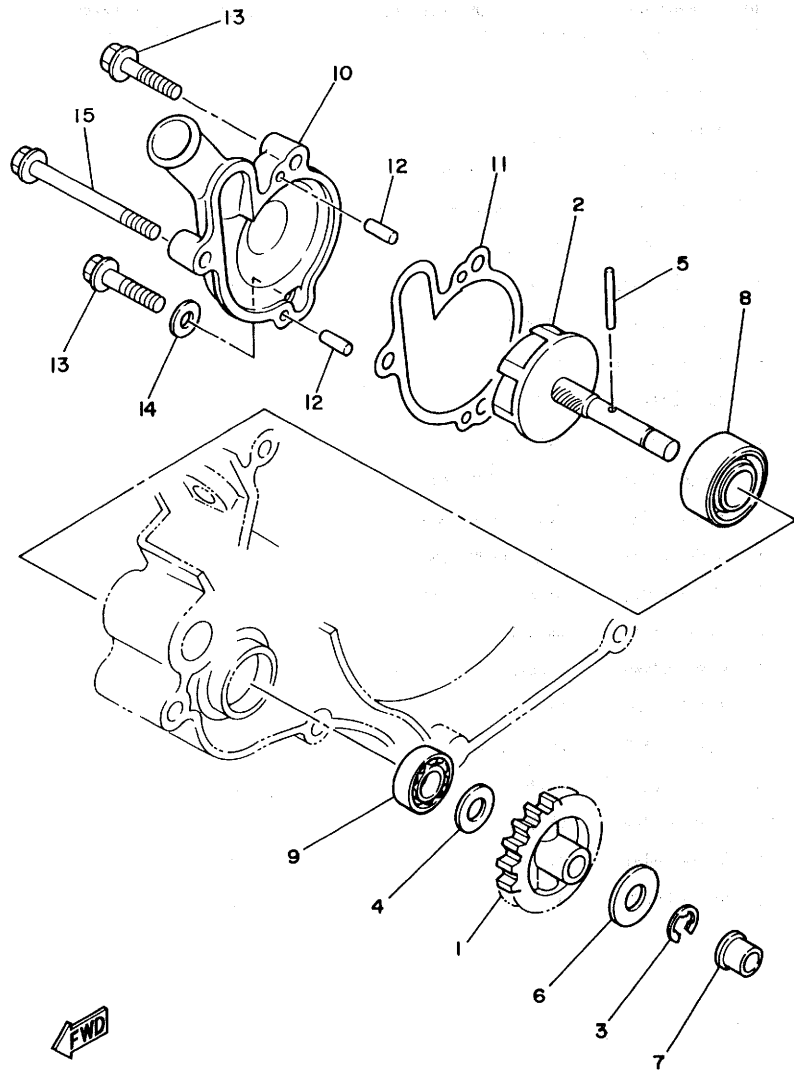

FIG. 4 WATER PUMP

REF. NO.	PART NO.	DESCRIPTION	Q'TY	REMARKS
1	3JD-12459-00	GEAR, impeller shaft	1	
2	1LX-12450-00	IMPELLER SHAFT ASSY	1	
3	99080-07600	CIRCLIP	1	
4	90201-08512	WASHER, plate	1	
5	93603-22028	PIN, dowel	1	
6	90201-08784	WASHER, plate	1	
7	90381-08002	BUSH, solid	1	
8	93103-10147	OIL SEAL	1	
9	93300-60814	BEARING (608M4ML01)	1	NMB
10	2VN-12422-01	COVER, housing	1	
11	1LX-12428-01	GASKET, housing cover 2	1	
12	93604-10011	PIN, dowel	2	
13	95023-06025	BOLT	2	
14	90430-06166	GASKET	1	
15	95021-06060	BOLT, flange	1	



3SR2100-0040

B6

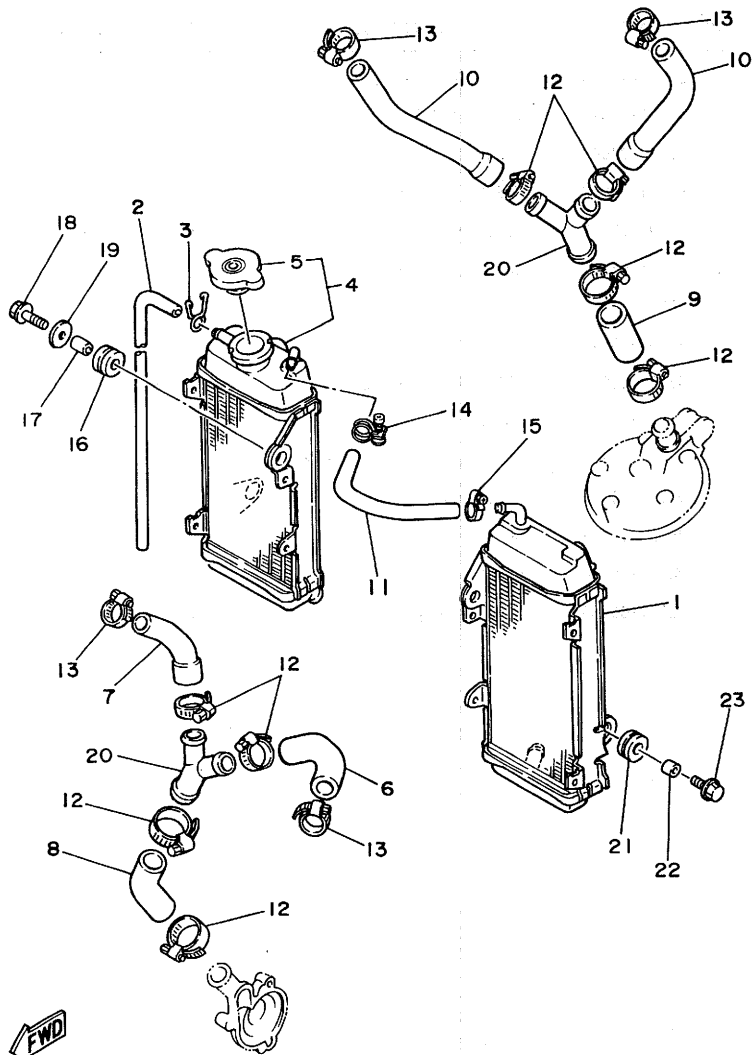

3XJ1100-1050

FIG. 5 RADIATOR. HOSE

REF. NO.	PART NO.	DESCRIPTION	Q'TY	REMARKS
1	3JD-1240A-00	RADIATOR ASSY 2	1	
2	90446-09013	HOSE	1	
3	90467-09006	CLIP	1	
4	1LX-1240A-00	RADIATOR ASSY 2	1	
5	22W-12462-00	.CAP, radiator	1	
6	3JD-12481-01	PIPE 1	1	
7	3JD-12482-00	PIPE 2	1	
8	3JD-12483-00	PIPE 3	1	
9	3JD-12485-00	PIPE 5	1	
10	3JD-12476-00	PIPE 6	2	
11	1LU-1248A-01	PIPE 8	1	
12	90450-28014	HOSE CLAMP ASSY	8	
13	90450-22052	HOSE CLAMP ASSY	4	
14	90450-15041	HOSE CLAMP ASSY	1	
15	90450-17036	HOSE CLAMP ASSY	1	
16	90480-15064	GROMMET	2	
17	90387-074W0	COLLAR	2	
18	95023-06030	BOLT	2	
19	90201-06570	WASHER, plate	2	
20	24X-12469-00	JOINT 1	2	
21	90480-18276	GROMMET	2	
22	90387-064W1	COLLAR	2	
23	95023-06020	BOLT	2	

B7

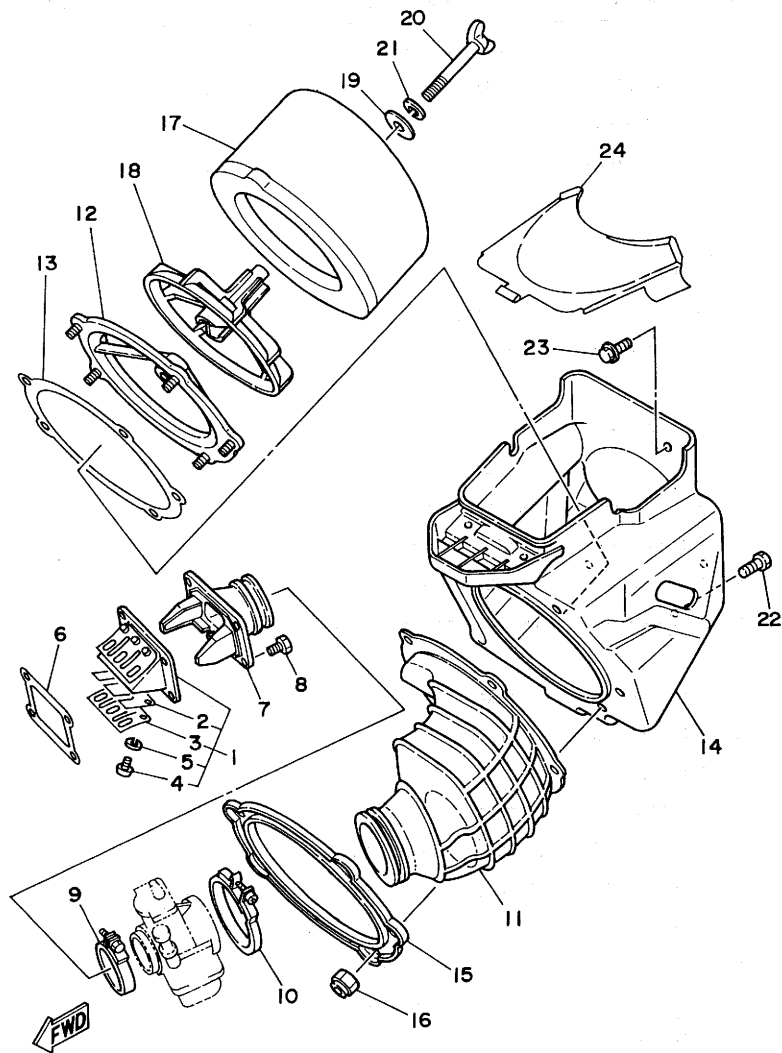

3XJ1100-1061

FIG. 6 INTAKE

REF. NO.	PART NO.	DESCRIPTION	Q'TY	REMARKS
1	2VN-13610-00	REED VALVE ASSY	1	
2	TRX-13613-00	.REED, valve	2	
3	2VN-13616-00	.STOPPER, reed valve	2	
4	98580-03008	.SCREW, pan head	6	
5	92990-03100	.WASHER, spring	6	
6	2K7-13621-10	GASKET, valve seat	1	
7	3SR-13565-00	JOINT, carburetor	1	
8	95023-06020	BOLT	4	
9	90460-51109	CLAMP, hose	1	
10	90460-68230	CLAMP, hose	1	
11	3XJ-14453-01	JOINT, air cleaner 1	1	
12	3JD-14459-00	HOLDER, guide	1	
13	3JD-14462-00	SEAL	1	
14	3XJ-W1441-01	AIR CLEANER CASE COMP.	1	
15	3JD-14477-00	PLATE	1	
16	95601-05100	NUT, u	5	
17	3JD-14451-00	ELEMENT, air cleaner	1	
18	3JD-14458-00	GUIDE	1	
19	90209-06096	WASHER	1	
20	90122-06030	BOLT, wing	1	
21	92990-06100	WASHER, spring	1	
22	95023-06010	BOLT	1	
23	90119-06185	BOLT, with washer	1	
24	3XJ-1441A-00	COVER, cleaner case 1	1	AP FOR AIR CLEANER COVER

B8

FIG. 7 CARBURETOR

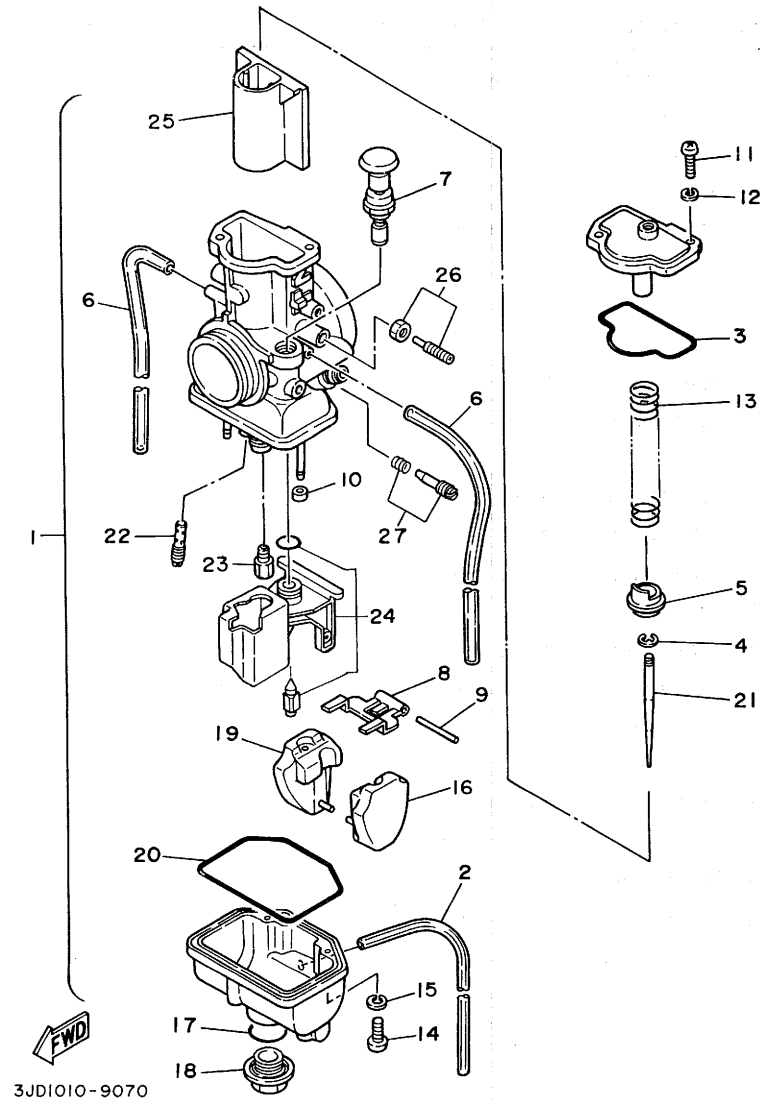

REF. NO.	PART NO.	DESCRIPTION	Q'TY	REMARKS
1	4DB-14101-00	CARBURETOR ASSY 1	1	UR
	4DB-14101-10	CARBURETOR ASSY 1	1	UR FOR EUROPE
2	55X-14196-00	.PIPE	1	
3	3JD-14147-00	.O-RING	1	
4	256-14919-00	.CLIP	1	
5	3JD-14194-00	.RING	1	
6	2HH-14197-00	.PIPE	2	
7	3JE-14171-00	.PLUNGER, starter	1	
8	363-14187-00	.ARM, float	1	
9	353-14186-00	.PIN, float	1	
10	214-14118-00	.CAP	2	
11	98511-04012	.SCREW, pan head	2	
12	92902-04100	.WASHER, spring	2	
13	3JD-14131-00	.SPRING, throttle valve	1	
14	98580-03010	.SCREW, pan head	1	
15	92990-03100	.WASHER, spring	1	
16	3JD-14185-00	.FLOAT	1	
17	3JE-14561-00	.O-RING	1	
18	4DB-14115-00	.PLUG, screw	1	
19	3JE-14185-00	.FLOAT	1	
20	3JE-14147-00	.O-RING	1	
21	3JD-14116-A4	.NEEDLE (J8-6EN15-56)	1	STD
	3JD-14116-A1	.NEEDLE (J8-6EN15-55)	1	AP
	3JD-14116-A5	.NEEDLE (J8-6EN15-57)	1	AP
22	3H1-14142-20	.JET, pilot (# 20)	1	STD
	3H1-14142-17	.JET, pilot (# 17.5)	1	AP
	3H1-14142-25	.JET, pilot (# 25)	1	AP
	3H1-14142-30	.JET, pilot (# 30)	1	AP

B9

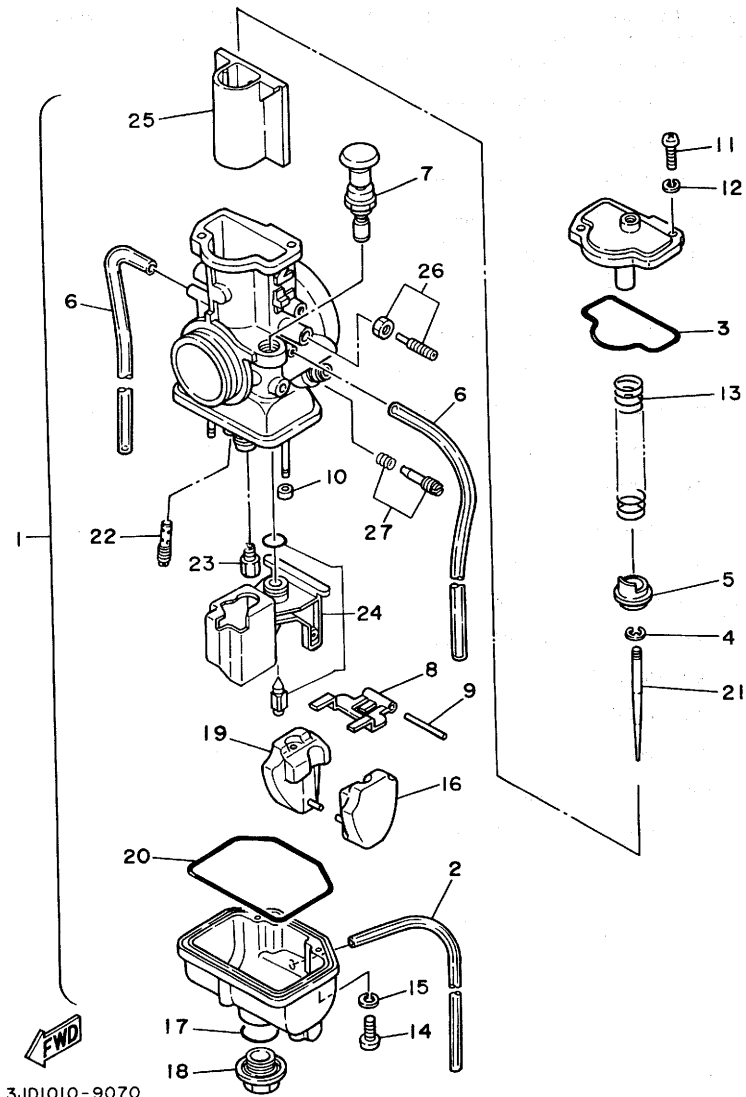

3JD1010-9070

FIG. 7 CARBURETOR

REF. NO.	PART NO.	DESCRIPTION	Q'TY	REMARKS
23	137-14143-66-A1	.JET, main (#330)	1	STD
	137-14143-62-A1	.JET, main (#310)	1	AP
	137-14143-64	.JET, main (#320)	1	AP
	137-14143-68	.JET, main (#340)	1	AP
	137-14143-70	.JET, main (#350)	1	AP
24	3JD-14107-35	.NEEDLE VALVE SET	1	
25	3JD-14112-55	.VALVE, throttle (C.A 5.5)	1	UR STD
	3JD-14112-60	.VALVE, throttle (C.A 6.0)	1	UR STD FOR EUROPE
	3JD-14112-50	.VALVE, throttle (C.A 5.0)	1	AP
26	3JD-14103-00	.THROTTLE SCREW SET	1	
27	3JD-14104-00	.AIR SCREW SET	1	

FIG. 8 EXHAUST

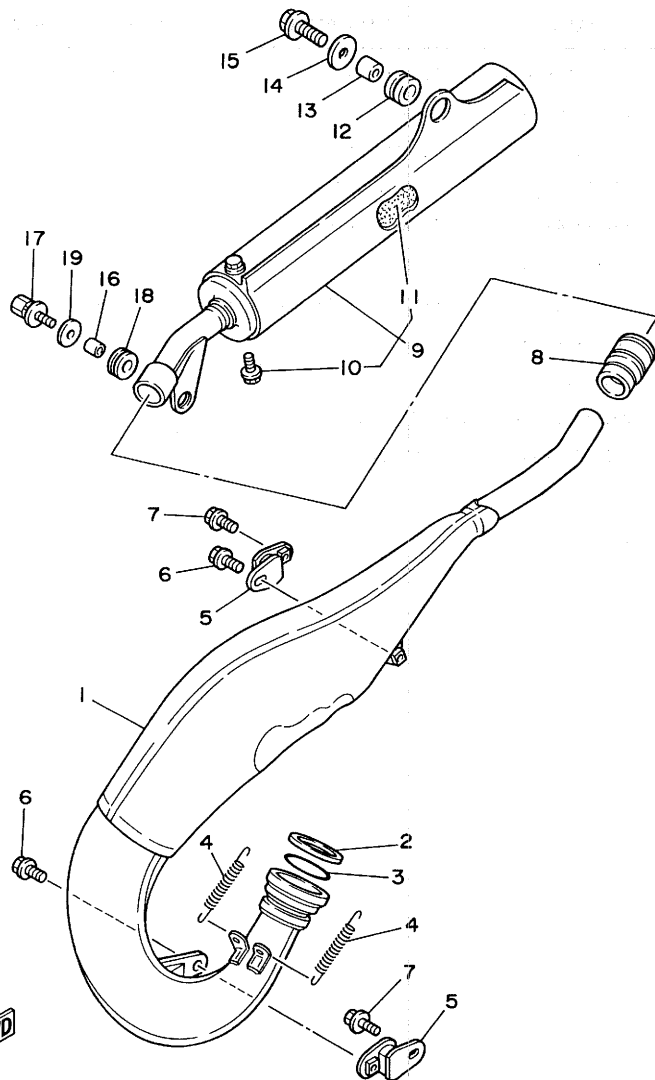

4DB2100-2080

REF. NO.	PART NO.	DESCRIPTION	Q'TY	REMARKS
1	4DB-14610-00	EXHAUST PIPE ASSY 1	1	
2	3R3-14613-00	GASKET, exhaust pipe	1	
3	93210-45742	O-RING	1	
4	90507-20030	SPRING, tension	2	
5	565-14771-00	STAY, muffler 1	2	
6	95023-06012	BOLT	2	
7	95023-06010	BOLT	2	
8	3M7-14615-00	JOINT, exhaust 1	1	
9	3XJ-14753-00	SILENCER, exhaust	1	UR
	3XJ-14753-10	SILENCER, exhaust	1	UR FOR JAPAN
10	95023-06008	.BOLT	2	
11	3XJ-1469A-00	.FIBER	1	UR
	3XJ-1469A-10	.FIBER	1	UR FOR JAPAN
12	39X-14747-00	DAMPER, muffler	1	
13	90387-100Y1	COLLAR	1	
14	90201-08612	WASHER, plate	1	
15	95023-08030	BOLT	1	
16	90387-060A7	COLLAR	1	
17	90109-064F4	BOLT	1	
18	90480-16233	GROMMET	1	
19	90201-06407	WASHER, plate	1	

B11

FIG. 9 CRANKCASE

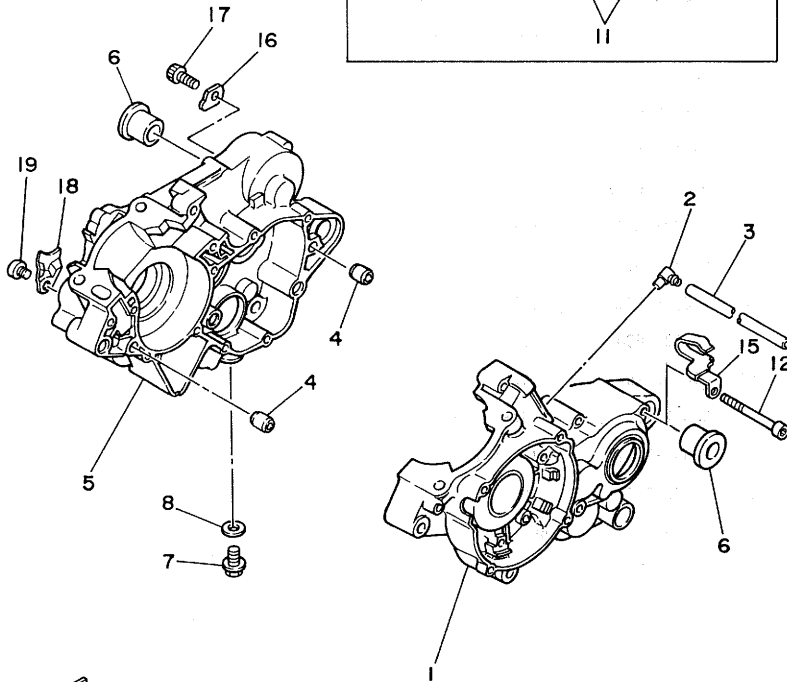
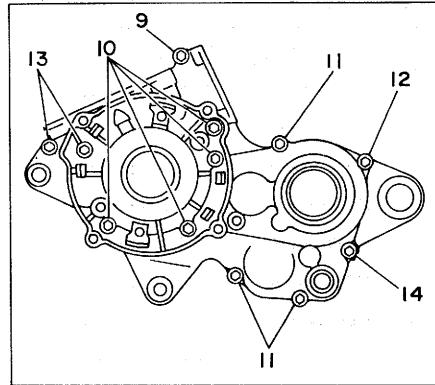

REF. NO.	PART NO.	DESCRIPTION	Q'TY	REMARKS
1	4DB-15111-00	CRANKCASE 1	1	
2	353-13115-01	CONNECTOR, suction pipe	1	
3	90445-08605	HOSE	1	
4	99510-12016	PIN, dowel	2	
5	1LX-15121-12	CRANKCASE 2	1	
6	90387-16781	COLLAR	2	
7	90340-12097	PLUG, straight screw	1	
8	90430-12207	GASKET	1	
9	91316-06035	BOLT	1	
10	91316-06045	BOLT	4	
11	91316-06055	BOLT	3	
12	91316-06070	BOLT	1	
13	91316-06060	BOLT	2	
14	91316-06065	BOLT	1	
15	90465-08336	CLAMP	1	
16	90209-06290	WASHER	1	
17	91316-05012	BOLT	1	
18	3R3-15128-01	HOLDER	1	
19	98511-08010	SCREW, pan head	1	



3JD1010-9090

B12

FIG. 10 CRANKCASE COVER 1

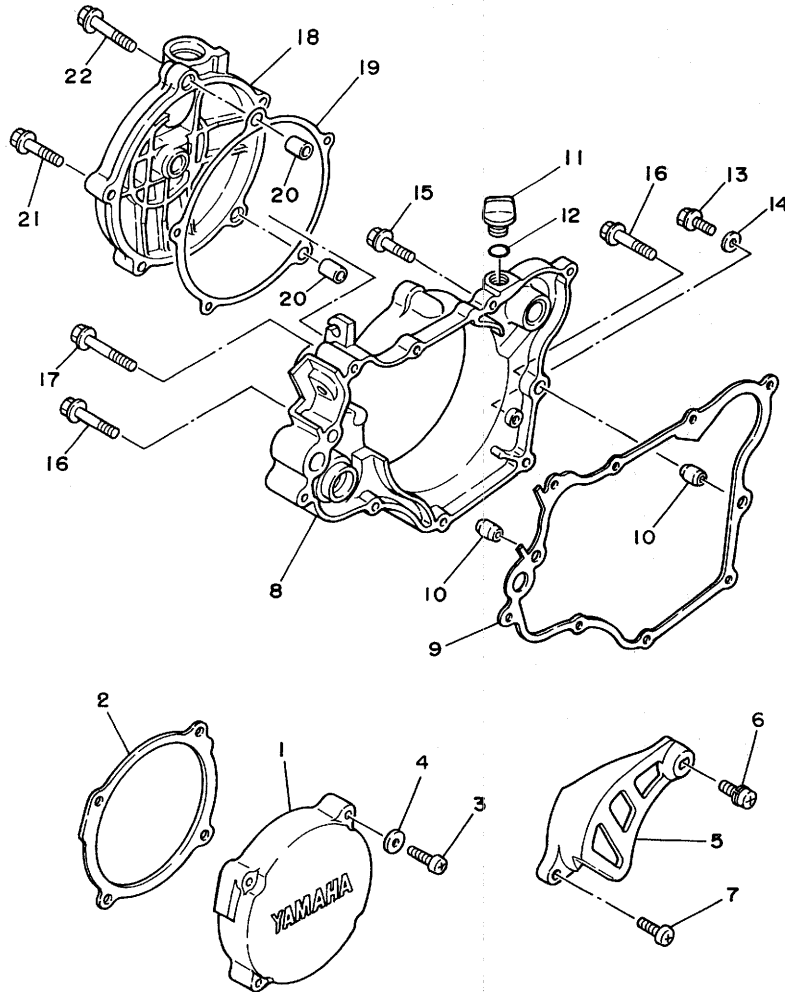

REF. NO.	PART NO.	DESCRIPTION	Q'TY	REMARKS
1	4DB-15411-00	COVER, crankcase 1	1	
2	4DB-15451-00	GASKET, crankcase cover 1	1	
3	98501-06030	SCREW, pan head	4	
4	92901-06600	WASHER, plate	4	
5	3SR-15421-00	COVER, crankcase 2	1	
6	90159-06146	SCREW, with washer	1	
7	98502-06016	SCREW, pan head	1	
8	3JD-15431-00	COVER, crankcase 3	1	
9	1LX-15462-10	GASKET, crankcase cover 3	1	
10	99530-10014	PIN, dowel	2	
11	1G8-15362-00	PLUG, oil level	1	
12	93210-14104	O-RING	1	
13	95023-06008	BOLT	1	
14	90430-06016	GASKET	1	
15	95023-06025	BOLT	6	
16	95023-06035	BOLT	2	
17	95023-06040	BOLT	1	
18	4DB-15415-00	COVER, generator	1	
19	3JD-15463-10	GASKET, carburetor cover 2	1	
20	99530-10014	PIN, dowel	2	
21	95023-06030	BOLT	3	
22	95023-06040	BOLT	2	

FWD
3SR2100-0100

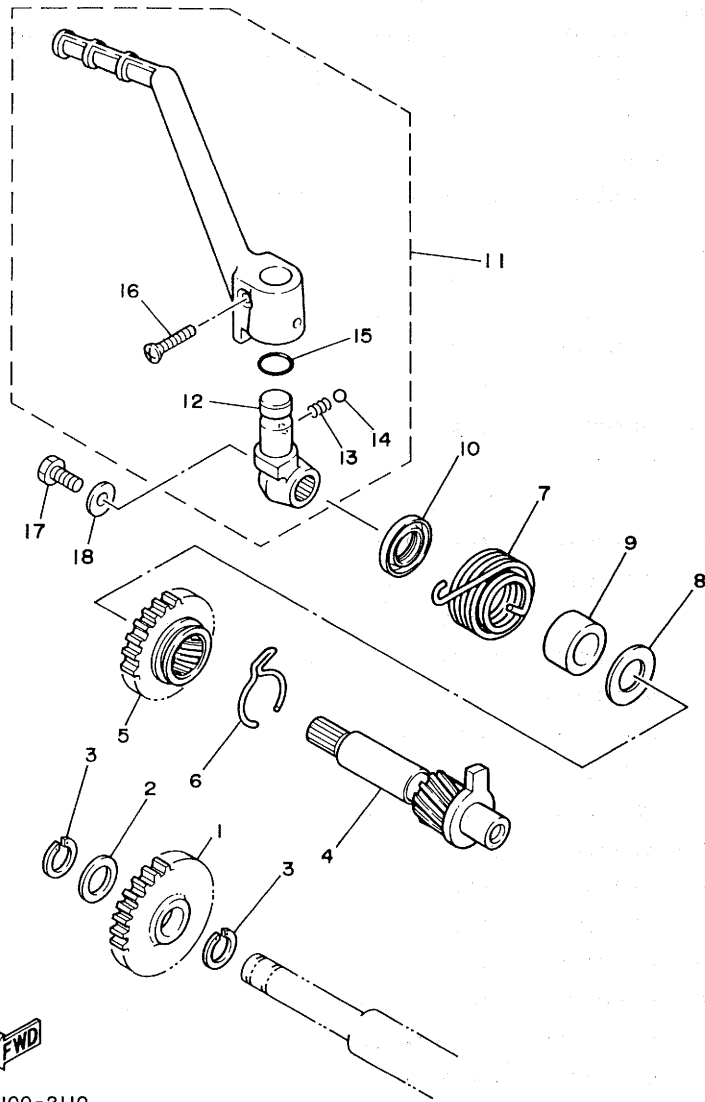
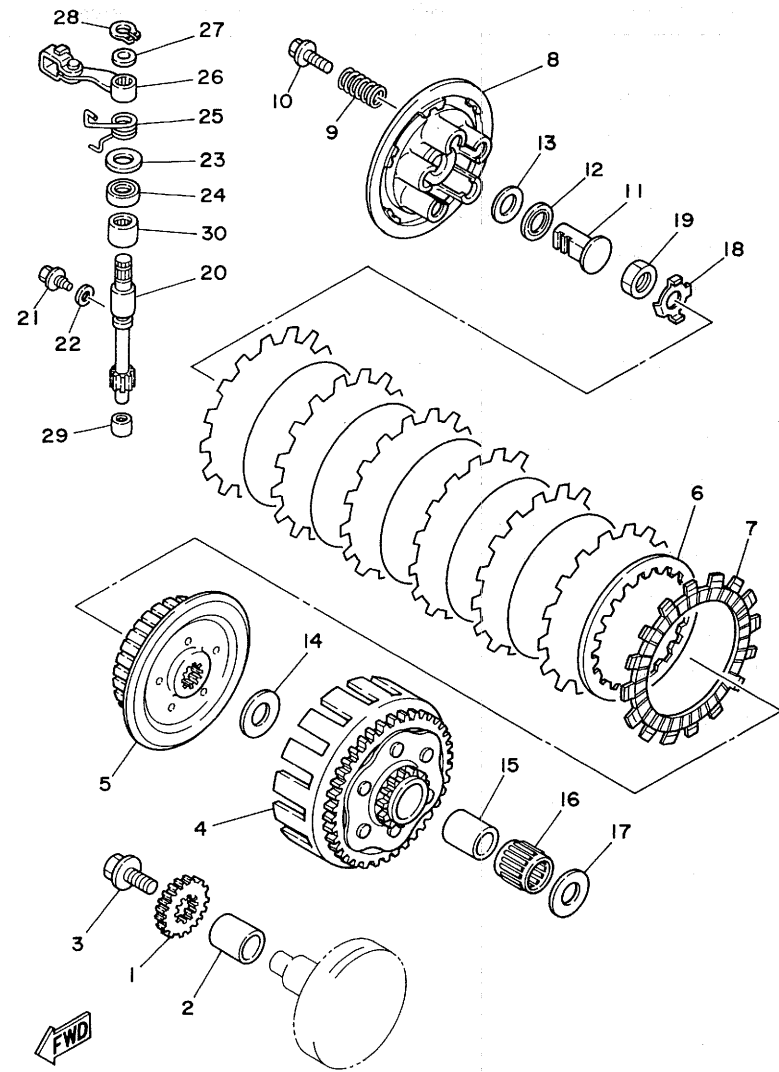

FIG. 11 STARTER

REF. NO.	PART NO.	DESCRIPTION	Q'TY	REMARKS
1	1LX-15651-00	GEAR, kick idle	1	
2	137-17417-00-05	SHIM 1 (0.5T)	1	
3	93440-15012	CIRCLIP	2	
4	1LX-15660-00	KICK AXLE ASSY	1	
5	1LX-15641-00	GEAR, kick	1	
6	90468-26048	CLIP	1	
7	90508-26700	SPRING, torsion	1	
8	90201-17164	WASHER, plate	1	
9	90560-17279	SPACER	1	
10	93102-17263	OIL SEAL	1	
11	4DB-15620-00	KICK CRANK ASSY	1	
12	4DB-15621-00	.BOSS, kick crank	1	
13	90501-12081	.SPRING, compression	1	
14	93507-32031	.BALL	1	
15	93210-15151	.O-RING	1	
16	90157-06048	.SCREW, pan head	1	
17	97021-06012	BOLT	1	
18	90201-065F3	WASHER, plate	1	

4DB2100-2110

B14



3XJ1100-1120

FIG. 12 CLUTCH

REF. NO.	PART NO.	DESCRIPTION	Q'TY	REMARKS
1	3XJ-16111-00	GEAR, primary drive	1	
2	90387-202T9	COLLAR	1	
3	90105-10445	BOLT, washer based	1	
4	3XJ-16150-00	PRIMARY DRIVEN GEAR COMP.	1	
5	3XJ-16371-00	BOSS, clutch	1	
6	3XJ-16324-00	PLATE, clutch 1	6	
7	3XJ-16321-00	PLATE, friction	7	
8	3XJ-16351-00	PLATE, pressure 1	1	
9	90501-23598	SPRING, compression	5	
10	90159-06016	SCREW, with washer	5	
11	3XJ-16356-00	ROD, push 1	1	
12	93340-21505	BEARING, thrust	1	
13	90201-150H2	WASHER, plate	1	
14	90201-204K8	WASHER, plate	1	
15	3XJ-16181-00	SPACER 1	1	
16	93310-225N0	BEARING, cylindrical	1	
17	3XJ-16164-00	PLATE, thrust 2	1	
18	90215-16245	WASHER, lock	1	
19	90170-16326	NUT	1	
20	4DB-16382-00	AXLE, push lever	1	
21	90109-06418	BOLT	1	
22	90430-06014	GASKET	1	
23	90201-12474	WASHER, plate	1	
24	93102-15212	OIL SEAL	1	
25	90508-14767	SPRING, torsion	1	
26	3JD-16340-00	PUSH LEVER ASSY	1	
27	90201-10119	WASHER, plate	1	
28	99009-10400	CIRCLIP	1	

B15

FIG. 12 CLUTCH

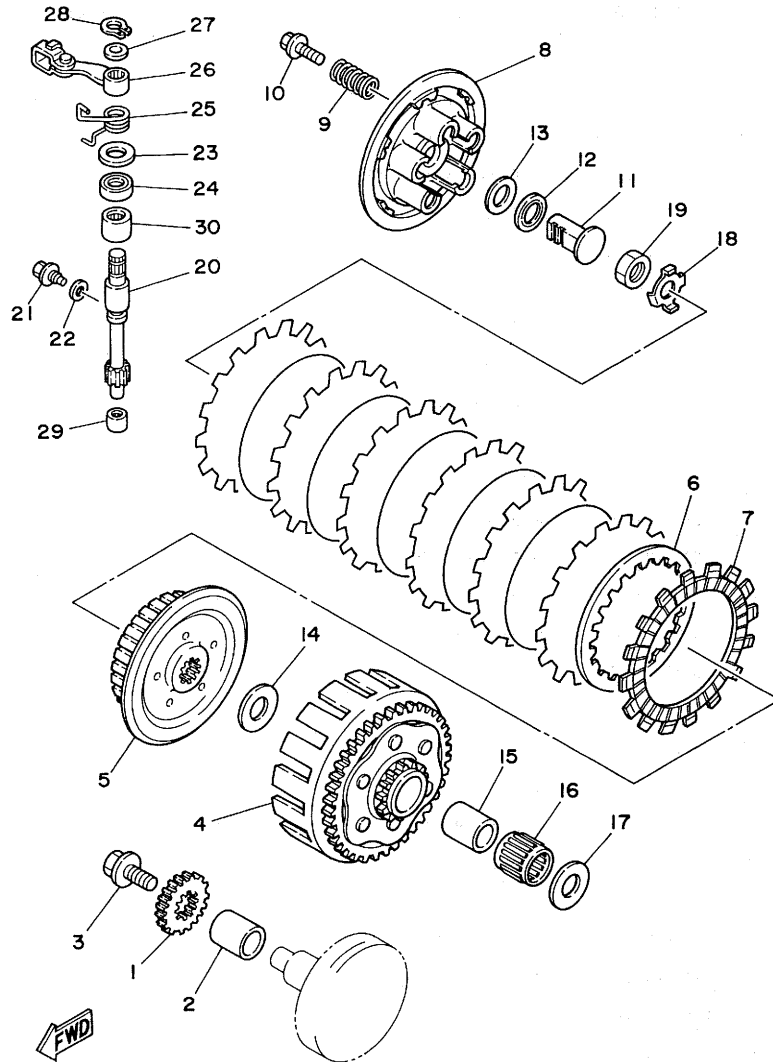

REF. NO.	PART NO.	DESCRIPTION	Q'TY	REMARKS
29	93315-10838	BEARING, cylindrical	1	
30	93315-31502	BEARING, cylindrical	1	

3XJ1100-1120

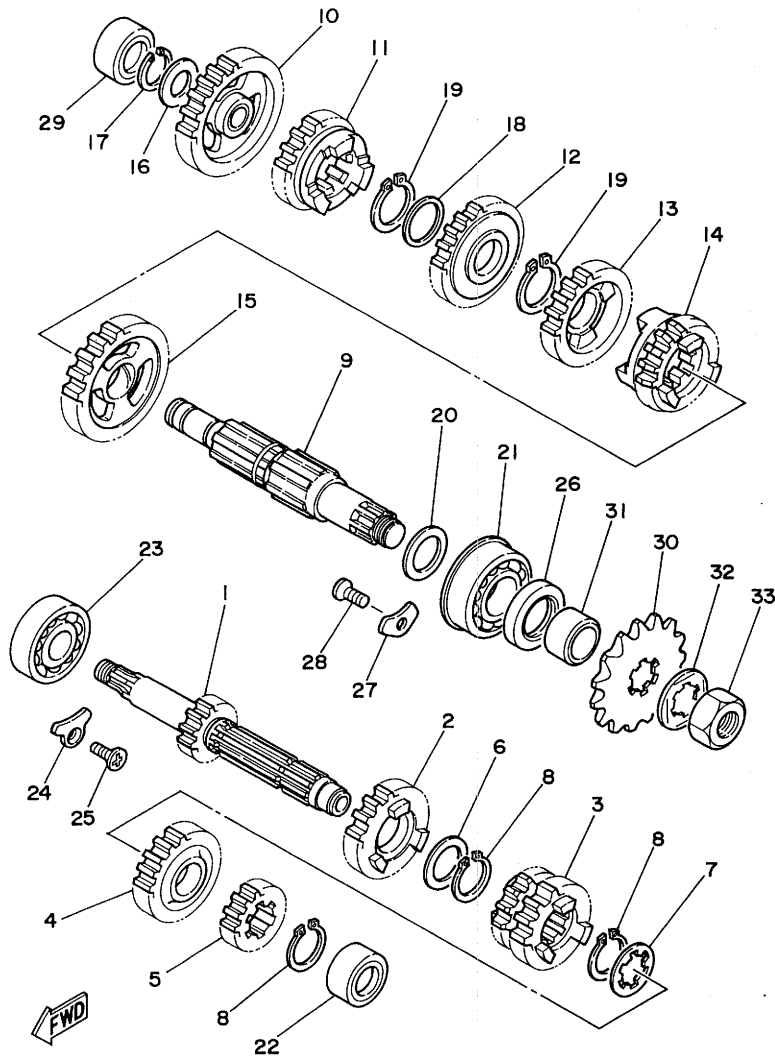

3XJ1100-1130

FIG. 13 TRANSMISSION

REF. NO.	PART NO.	DESCRIPTION	Q'TY	REMARKS
1	3XJ-17411-00	AXLE, main	1	
2	3JD-17151-00	GEAR, 5th pinion (20T)	1	
3	3SR-17131-00	GEAR, 3rd pinion	1	
4	3JD-17161-00	GEAR, 6th pinion (21T)	1	
5	3SR-17121-00	GEAR, 2nd pinion	1	
6	90201-22555	WASHER, plate	1	
7	90209-18135	WASHER	1	
8	93410-22039	CIRCLIP	3	
9	3XJ-17421-00	AXLE, drive	1	
10	1LX-17211-01	GEAR, 1st wheel	1	
11	3JD-17251-00	GEAR, 5th wheel (23T)	1	
12	3SR-17231-00	GEAR, 3rd wheel	1	
13	1LX-17241-00	GEAR, 4th wheel (22T)	1	
14	3XJ-17261-00	GEAR, 6th wheel	1	
15	3XJ-17221-00	GEAR, 2nd wheel	1	
16	90201-15701	WASHER, plate (1.0T)	1	
17	93440-15012	CIRCLIP	1	
18	90209-18208	WASHER	1	
19	93410-22039	CIRCLIP	2	
20	90201-206K8	WASHER, plate	1	
21	93306-30411	BEARING (B6304)	1	
22	93311-41530	BEARING, cylindrical	1	
23	93306-20431	BEARING (B6204Z)	1	
24	1LX-15383-00	PLATE, bearing cover	1	
25	98701-06012	SCREW, flat head	1	
26	93102-26042	OIL SEAL	1	
27	3XJ-15383-00	PLATE, bearing cover	2	
28	98701-06012	SCREW, flat head	2	

C3

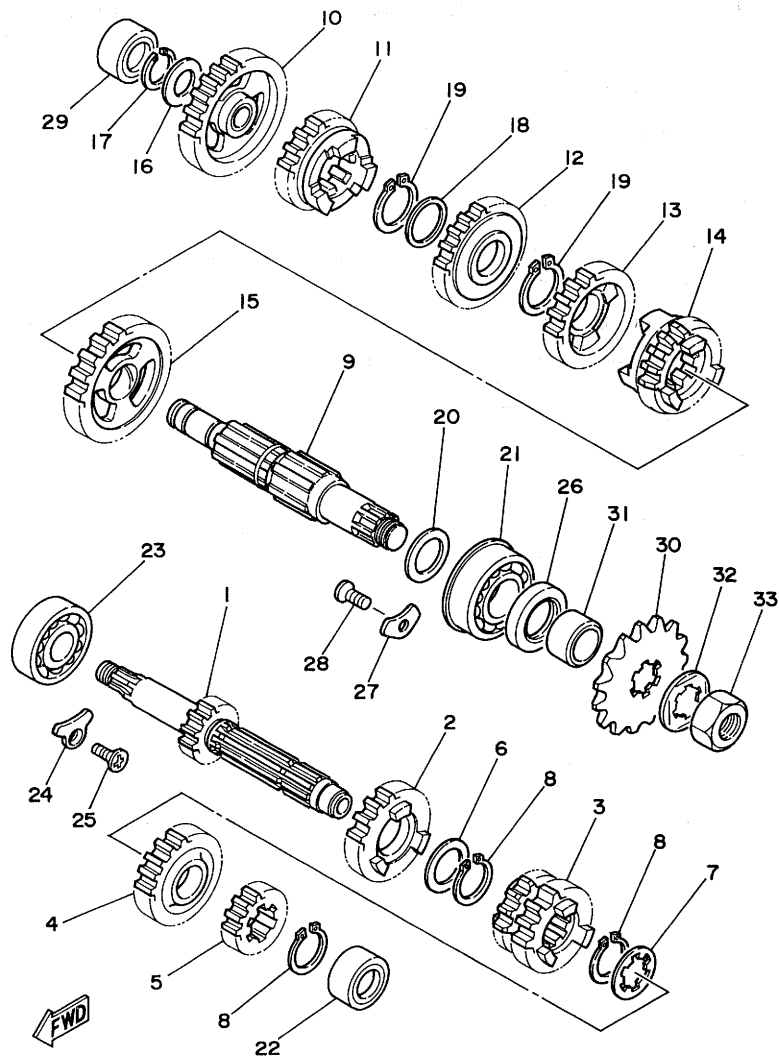

3XJ1100-1130

FIG. 13 TRANSMISSION

REF. NO.	PART NO.	DESCRIPTION	Q'TY	REMARKS
29	93311-31567	BEARING, cylindrical	1	
30	9383A-13031	SPROCKET, drive 13T (2HG1746130)	1	STD
	9383A-12017	SPROCKET, drive 12T (2HG1746120)	1	AP
	9383A-14054	SPROCKET, drive 14T (2HG1746140)	1	AP
31	90387-202A0	COLLAR	1	
32	90215-20261	WASHER, lock	1	
33	90179-16226	NUT	1	

C4

FIG. 14 SHIFT CAM. FORK

REF. NO.	PART NO.	DESCRIPTION	Q'TY	REMARKS
1	3XJ-18540-01	SHIFT CAM ASSY	1	
2	3XJ-18140-00	STOPPER LEVER ASSY	1	
3	90508-240A7	SPRING, torsion	1	
4	3XK-18177-00	BOLT, stopper	1	
5	3JD-18511-01	FORK, shift 1	1	
6	2VN-18512-01	FORK, shift 2	1	
7	1LX-18513-01	FORK, shift 3	1	
8	1LX-18531-00	BAR, shift fork guide 1	1	
9	1LX-18535-00	BAR, shift fork guide 2	1	
10	90201-34683	WASHER, plate	1	

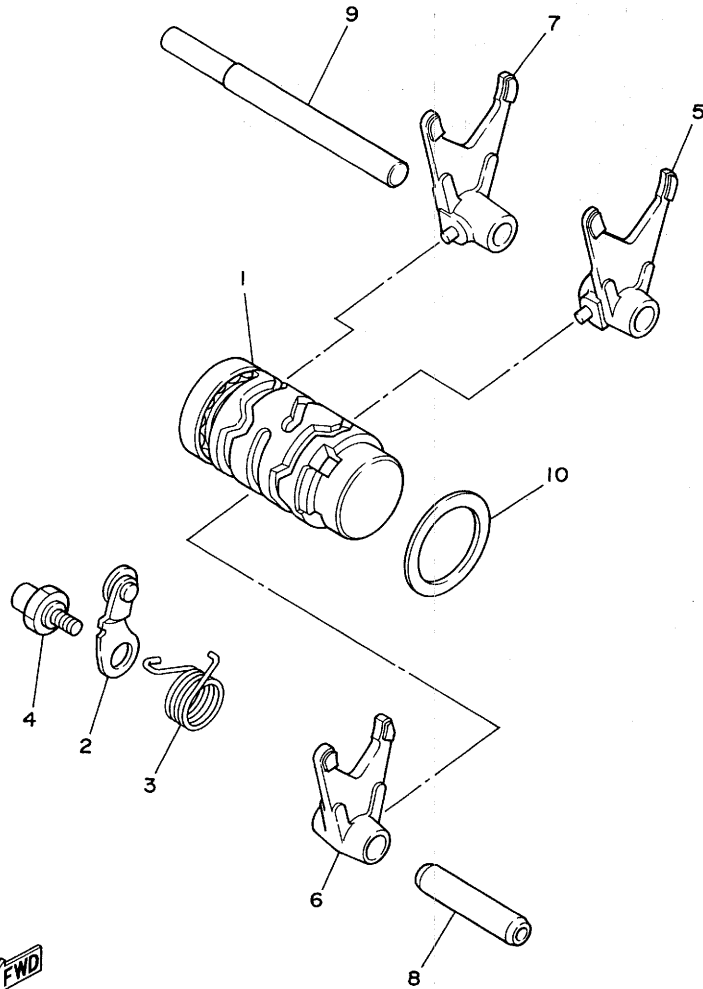

3XJ1100-1140

C5

FIG. 15 SHIFT SHAFT

REF. NO.	PART NO.	DESCRIPTION	Q'TY	REMARKS
1	3XJ-18101-02	SHIFT SHAFT ASSY	1	
2	3XJ-18122-00	LEVER, shift 2	1	
3	90508-290A8	SPRING, torsion	1	
4	90560-12280	SPACER	1	
5	1LX-18110-02	SHIFT PEDAL ASSY	1	
6	97011-06025	BOLT	1	
7	93109-12012	OIL SEAL	1	
8	3XJ-18173-00	PIN, shift	1	
9	3XJ-18178-00	ROLLER, shift lever	1	
10	3XJ-18182-00	PAWL, shifter	2	
11	90501-05265	SPRING, compression	2	
12	3XJ-18184-00	PIN, pawl	2	
13	3XJ-18172-00	GUIDE, shift	1	
14	90101-06664	BOLT	2	
15	3XJ-18185-00	SEGMENT	1	

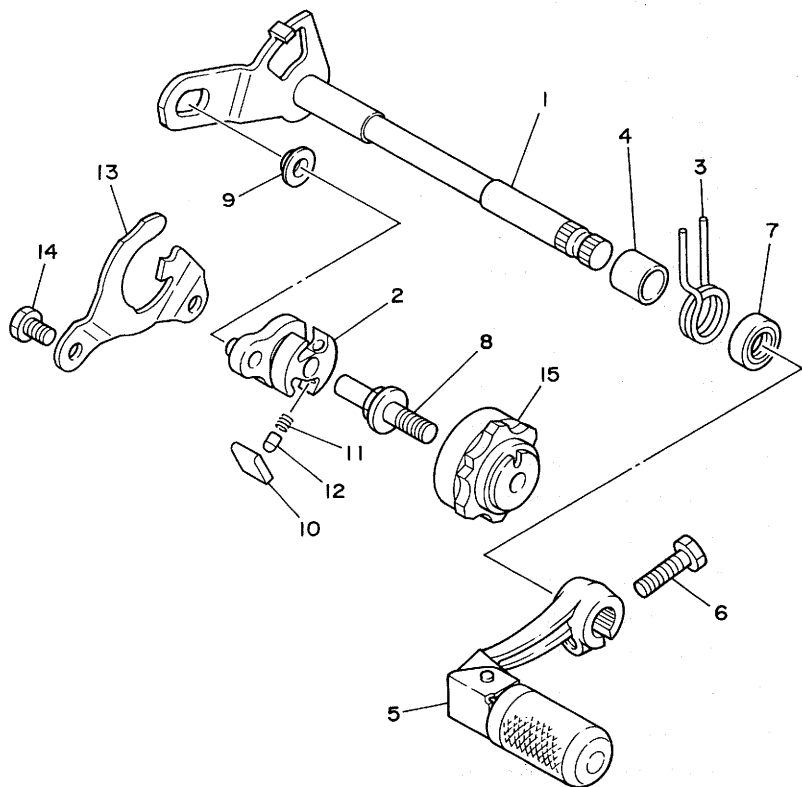

← FWD
3XJ1100-1150

C6

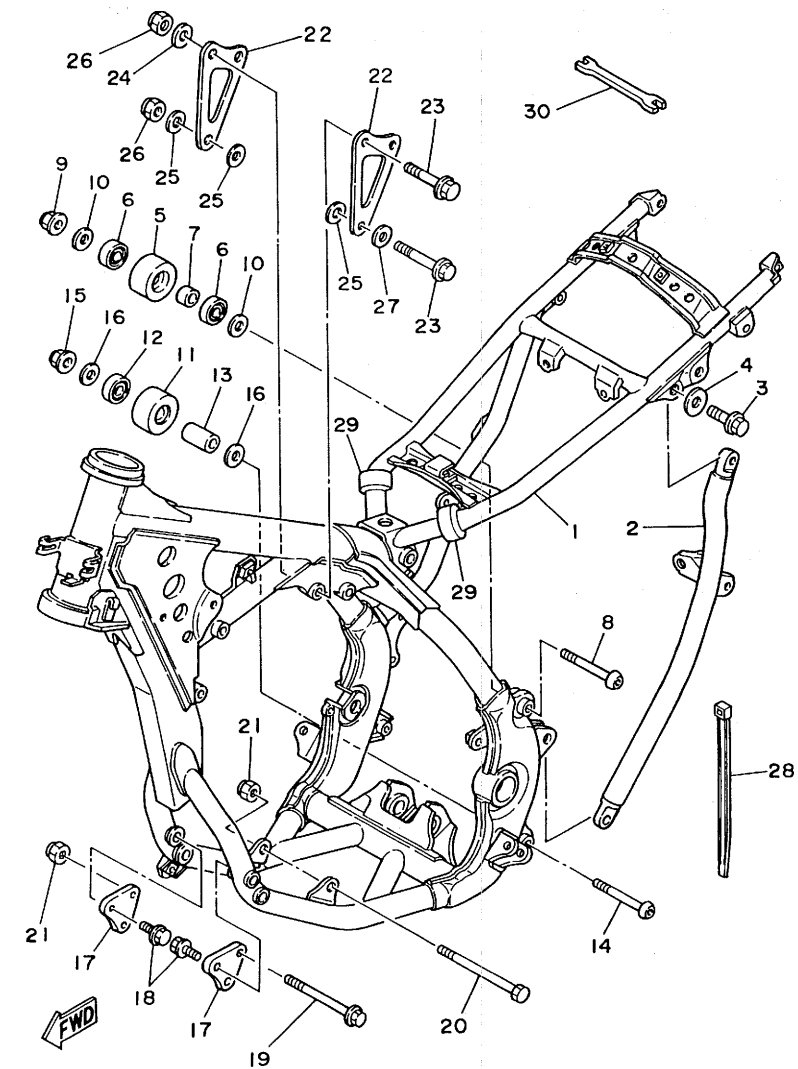

4DB2100-2160

FIG. 16 FRAME

REF. NO.	PART NO.	DESCRIPTION	Q'TY	REMARKS
1	4DB-21110-00-UJ	FRAME COMP.	1	RADICAL WHITE
2	3XK-21123-00-T9	BACK, stay (L.H)	1	COMPETITION SILVER
3	90101-08461	BOLT	2	
4	90201-080E2	WASHER, plate	2	
5	3JD-22178-00	TENSIONER	1	
6	93300-60816	BEARING	2	
7	90387-087K5	COLLAR	1	
8	92011-08070	BOLT, button head	1	
9	95601-08200	NUT, self-locking	1	
10	90201-081A6	WASHER, plate	2	
11	3JD-22178-10	TENSIONER	1	
12	93300-60816	BEARING	1	
13	90387-086N4	COLLAR	1	
14	92011-08070	BOLT, button head	1	
15	95601-08200	NUT, self-locking	1	
16	90201-081A6	WASHER, plate	2	
17	1LX-21419-01	BRACKET, engine 2	2	
18	95811-08040	BOLT, flange	4	
19	95811-08095	BOLT, flange	1	
20	90109-08386	BOLT	1	
21	95601-08200	NUT, self-locking	2	
22	1LX-21425-00	BRACKET, rear upper 1	2	
23	95811-08055	BOLT, flange	3	
24	90202-08022	WASHER, plate	2	
25	90201-085E6	WASHER, plate	3	
26	95601-08200	NUT, self-locking	3	
27	90201-084K3	WASHER, plate	1	
28	12R-82591-00	BAND	1	

C7

FIG. 16 FRAME

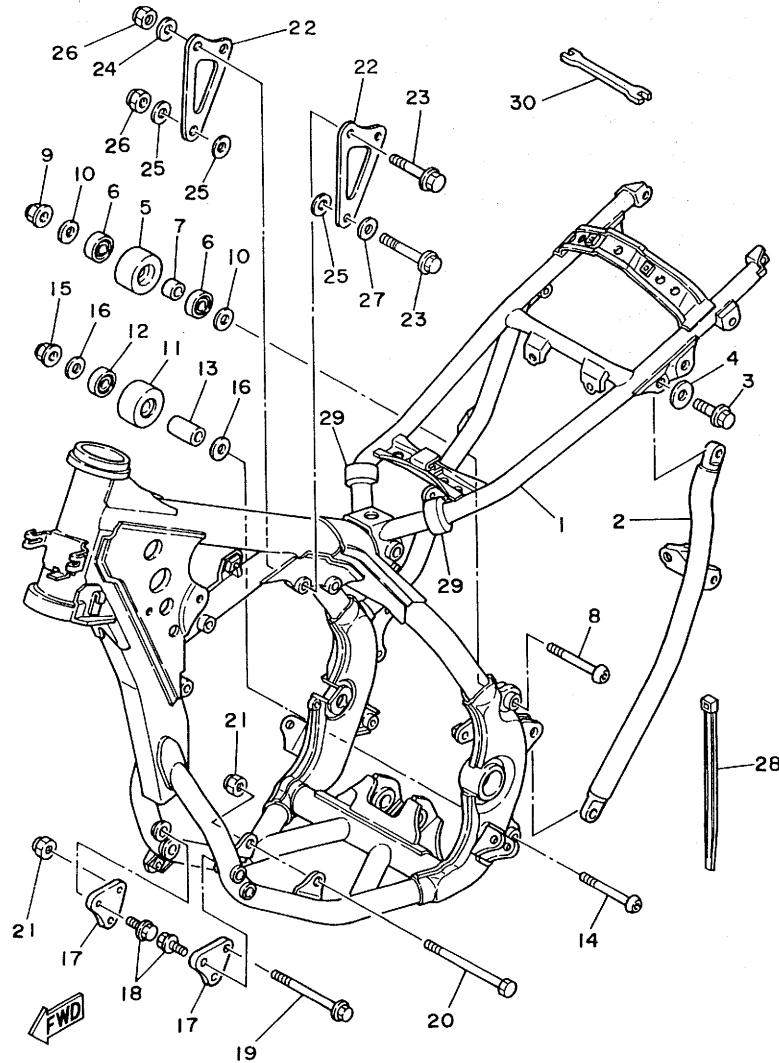

REF. NO.	PART NO.	DESCRIPTION	Q'TY	REMARKS
29	3XJ-21717-00	DAMPER, side cover	2	
30	56A-28166-00	WRENCH, hexagon	1	

4DB2100-2160

FIG. 17 FENDER

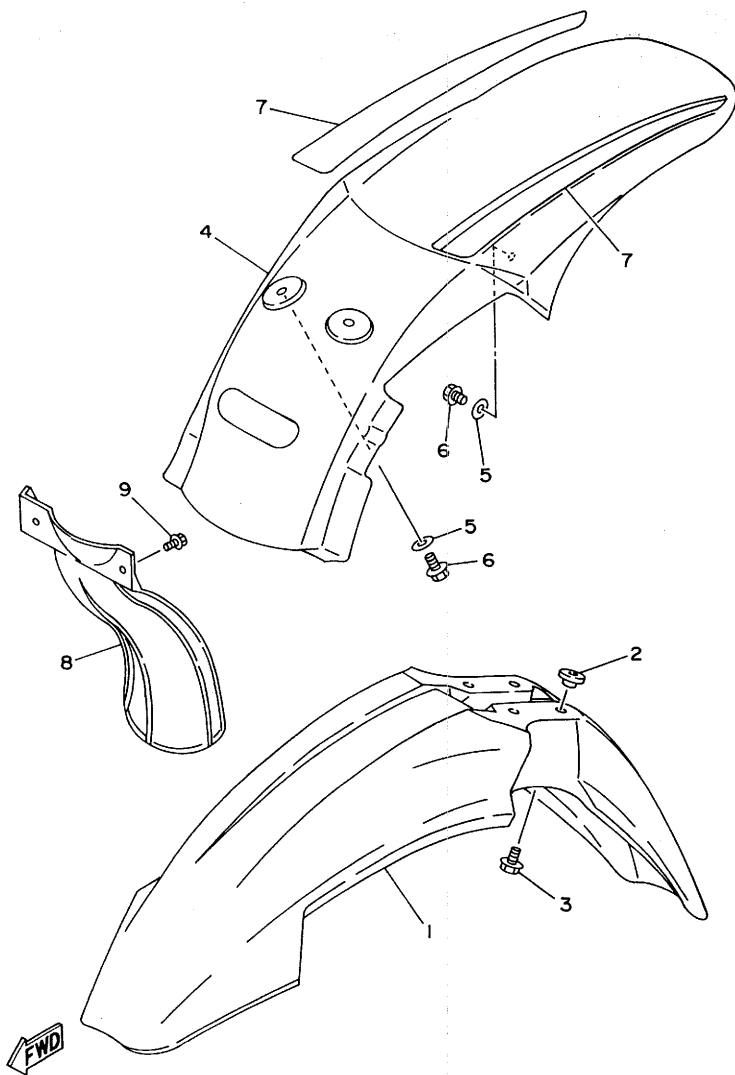

REF. NO.	PART NO.	DESCRIPTION	Q'TY	REMARKS
1	4DA-21511-00	FENDER, front	1	
2	3JD-21748-00	COLLAR	4	
3	90119-06063	BOLT, with washer	4	
4	3XJ-21611-02	FENDER, rear	1	
5	90201-06571	WASHER, plate	4	
6	90105-06553	BOLT, washer based	4	
7	4DA-2165A-00	GRAPHIC SET, rear fender	1	
8	39X-21642-00	GUARD, flap	1	
9	90119-06185	BOLT, with washer	2	

4DB2100-2170

C9

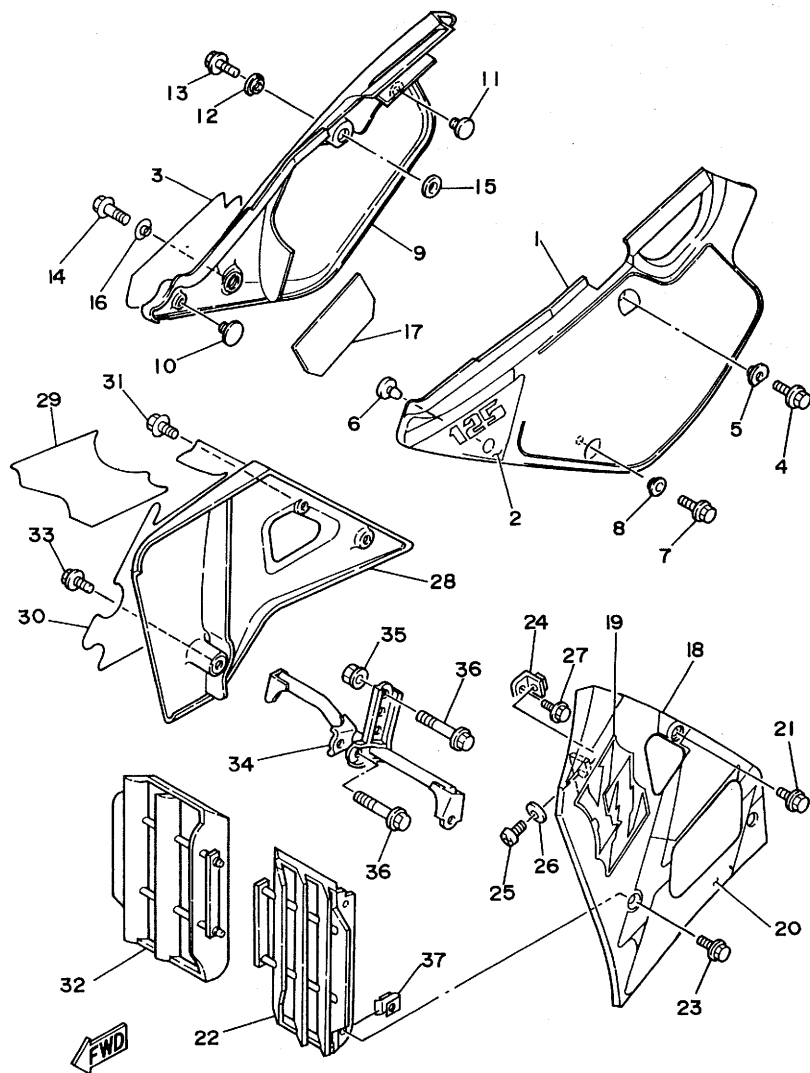

4DB2100-2180

FIG. 18 SIDE COVER

REF. NO.	PART NO.	DESCRIPTION	Q'TY	REMARKS
1	3XJ-21711-01	COVER, side 1	1	
2	4DB-2173E-00	GRAPHIC 1	1	
3	4DB-2173F-00	GRAPHIC 2	1	
4	95023-08020	BOLT	1	
5	90387-084X5	COLLAR	1	
6	22W-24181-00	DAMPER, locating 1	1	
7	91021-06016	BOLT, flange	1	
8	90387-064X4	COLLAR	1	
9	3XJ-21721-01	COVER, side 2	1	
10	22W-24181-00	DAMPER, locating 1	1	
11	3JD-24181-00	DAMPER, locating 1	1	
12	90387-084X5	COLLAR	1	
13	95023-08020	BOLT	1	
14	95811-06012	BOLT, flange	1	
15	92901-08200	WASHER, plain	1	
16	90387-064X4	COLLAR	1	
17	3XJ-2174A-00	INSULATOR, side cover	1	
18	3XJ-21731-01	COVER, side 3	1	
19	4DB-24244-00	GRAPHIC, fuel tank 1	1	
20	4DB-24250-02	GRAPHIC SET	1	
21	90119-06192	BOLT, with washer	2	
22	3XJ-2172A-00	PANEL 1	1	
23	90119-05193	BOLT, with washer	1	
24	2VM-2172K-00	BRACKET 1	1	
25	98501-05016	SCREW, pan head	1	
26	92990-05200	WASHER, plain	1	
27	90119-05193	BOLT, with washer	1	
28	3XJ-21741-01	COVER, side 4	1	

C10

FIG. 18 SIDE COVER

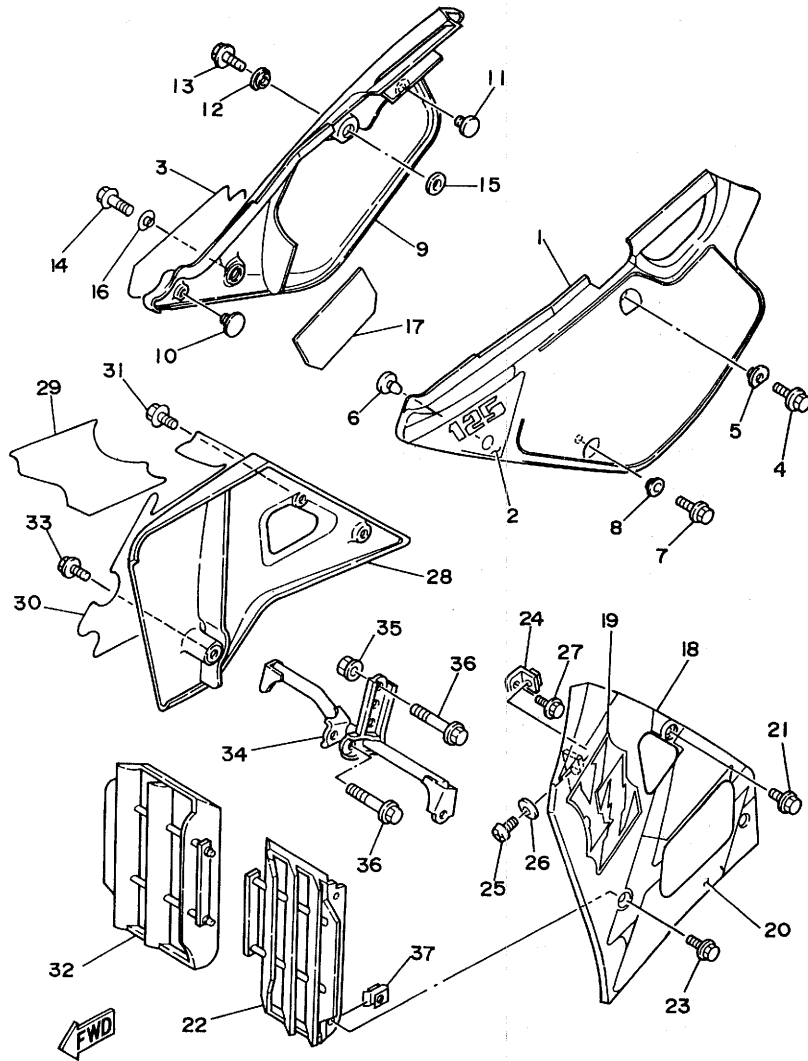

REF. NO.	PART NO.	DESCRIPTION	Q'TY	REMARKS
29	4DB-24245-00	GRAPHIC, fuel tank 2	1	
30	4DB-24249-02	GRAPHIC, fuel tank 6	1	
31	90119-06192	BOLT, with washer	2	
32	3XJ-2172F-00	PANEL 2	1	
33	90119-05193	BOLT, with washer	2	
34	3JD-2174F-00	GUARD, radiator	1	
35	95701-08500	NUT, flange	1	
36	95023-08050	BOLT	2	
37	22W-21791-00	NUT	4	

4DB2100-2180

C11

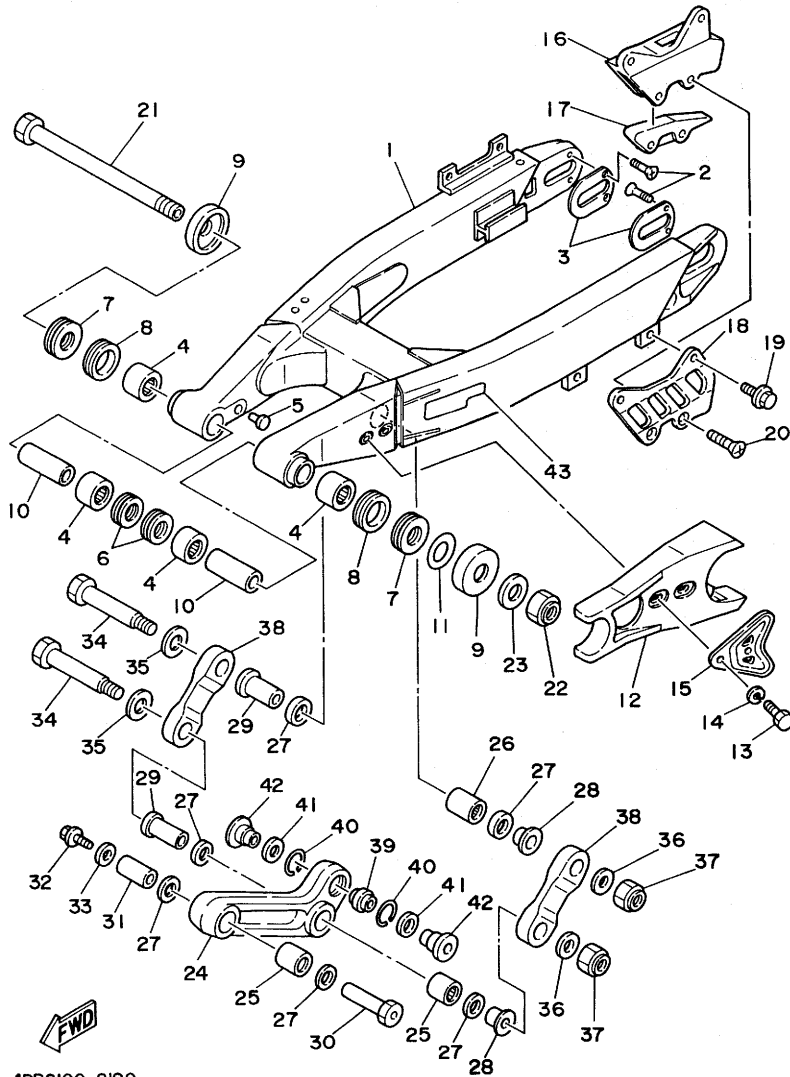
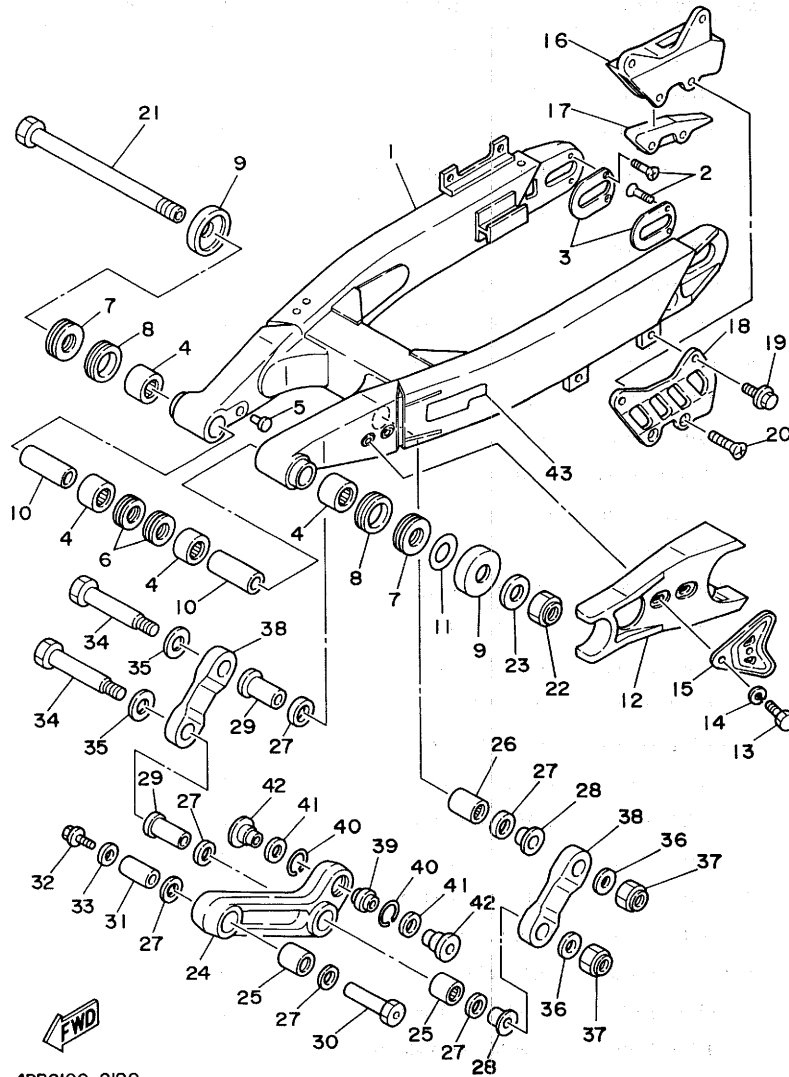

FIG. 19 REAR ARM

REF. NO.	PART NO.	DESCRIPTION	Q'TY	REMARKS
1	3XJ-22110-01	REAR ARM COMP.	1	
2	90151-04048	SCREW, countersunk	4	
3	3XJ-22355-00	PATCH A	2	
4	93317-22262	BEARING, cylindrical	4	UR
	93317-22263	BEARING, cylindrical	4	UR
5	90338-10150	PLUG	2	
6	93106-22019	OIL SEAL (DC 22-28-8)	2	
7	93342-22208	BEARING, thrust	2	
8	93108-35004	OIL SEAL (35-41-8)	2	
9	3R4-22129-00	COVER, thrust 2	2	
10	90380-16056	BUSH, solid	2	
11	156-22127-00	SHIM (0.3T)	1	
12	3JD-22151-00	SEAL, guard	1	
13	95023-06020	BOLT	2	
14	92990-06100	WASHER, spring	2	
15	3JD-22156-00	WASHER, plate	1	
16	3JD-22199-00	SUPPORT, chain	1	
17	3JD-22147-00	PROTECTOR, chain	1	
18	3JD-22128-00	COVER, thrust 1	1	
19	91001-06020	BOLT, flange	2	
20	98701-06035	SCREW, flat head	2	
21	1LX-22141-00	SHAFT, pivot	1	
22	90185-16127	NUT, self-locking	1	
23	90201-164H4	WASHER, plate	1	
24	3XJ-2217A-00	ARM, relay	1	
25	93315-22046	BEARING, cylindrical	2	
26	93315-22046	BEARING, cylindrical	1	
27	93109-20029	OIL SEAL	6	

C12

FIG. 19 REAR ARM



REF. NO.	PART NO.	DESCRIPTION	Q'TY	REMARKS
28	90387-164N2	COLLAR	2	
29	90387-164N3	COLLAR	2	
30	90179-10544	NUT	1	
31	90387-167R5	COLLAR	1	
32	95811-10016	BOLT, flange	1	
33	90201-106F2	WASHER, plate	1	
34	90109-142F4	BOLT	2	
35	90201-164H4	WASHER, plate	2	
36	90201-14740	WASHER, plate	2	
37	90185-14070	NUT, self-locking	2	
38	3XJ-2217F-00	ROD, connecting 1	2	
39	93399-99935	BEARING	1	
40	93440-30113	CIRCLIP	2	
41	3XJ-22475-00	SEAL, dust	2	
42	90387-103X9	COLLAR	2	
43	3XJ-2218A-00	EMBLEM, rear arm	2	

4DB2100-2190

C13

FIG. 20 REAR SUSPENSION

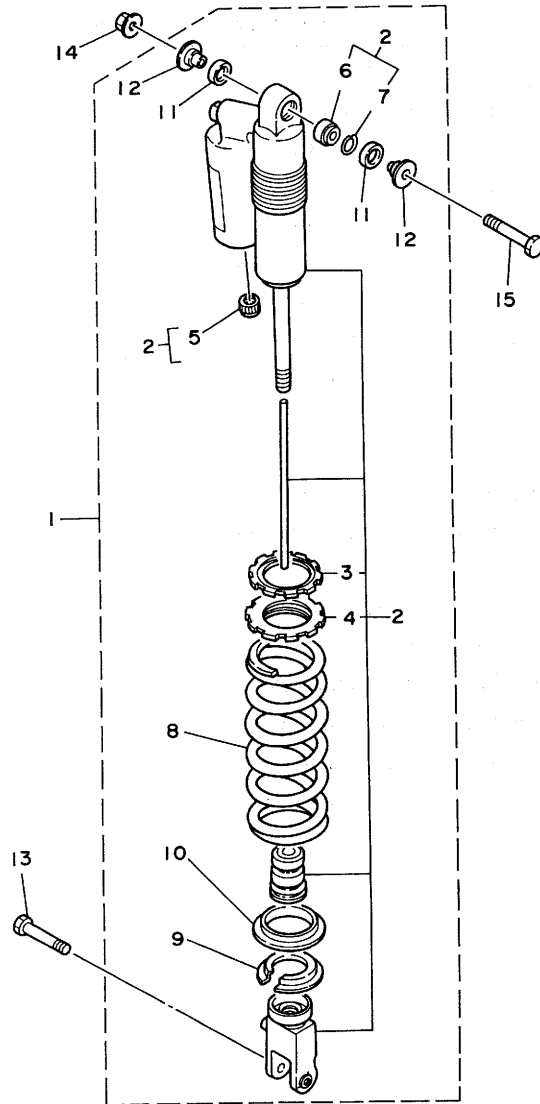

3XJ1100-1200

REF. NO.	PART NO.	DESCRIPTION	Q'TY	REMARKS
1	4DA-22210-00	SHOCK ABSORBER ASSY, rear	1	UR FOR USA, OCEANIA, S.AFRICA, OTHERS
	4DB-22210-10	SHOCK ABSORBER ASSY, rear	1	UR FOR EUROPE
	4DB-22210-20	SHOCK ABSORBER ASSY, rear	1	UR FOR JAPAN
	4DB-22210-30	SHOCK ABSORBER ASSY, rear	1	UR FOR CANADA
2	4DA-22210-00	.DAMPER SUB ASSY	1	UR FOR USA, OCEANIA, S.AFRICA, OTHERS
	4DB-22201-10	.DAMPER SUB ASSY	1	UR FOR EUROPE
	4DB-22201-20	.DAMPER SUB ASSY	1	UR FOR JAPAN
	4DB-22201-30	.DAMPER SUB ASSY	1	UR FOR CANADA
3	3SP-22234-00	..GUIDE, spring 3	1	
4	3SP-22213-00	..SEAT, spring upper	1	
5	24M-23184-00	..CAP, air valve	1	
6	3JD-22216-00	..BUSH, rear shock absorber	1	
7	43M-22274-00	..RING, stop	1	
8	3XJ-22212-01	..SPRING (K=4.6)	1	UR
	3XJ-22212-11	..SPRING (K=4.8)	1	UR FOR EUROPE
9	3JD-22214-00	..GUIDE, spring 1	1	
10	3JD-22224-00	..GUIDE, spring 2	1	
11	3JD-22475-00	..SEAL, dust	2	
12	3XJ-22253-00	..COLLAR, distance	2	
13	90105-10614	BOLT, washer based	1	
14	95611-10200	NUT, self-locking	1	
15	3SP-22241-00	BOLT 1	1	

C14

FIG. 21 STEERING

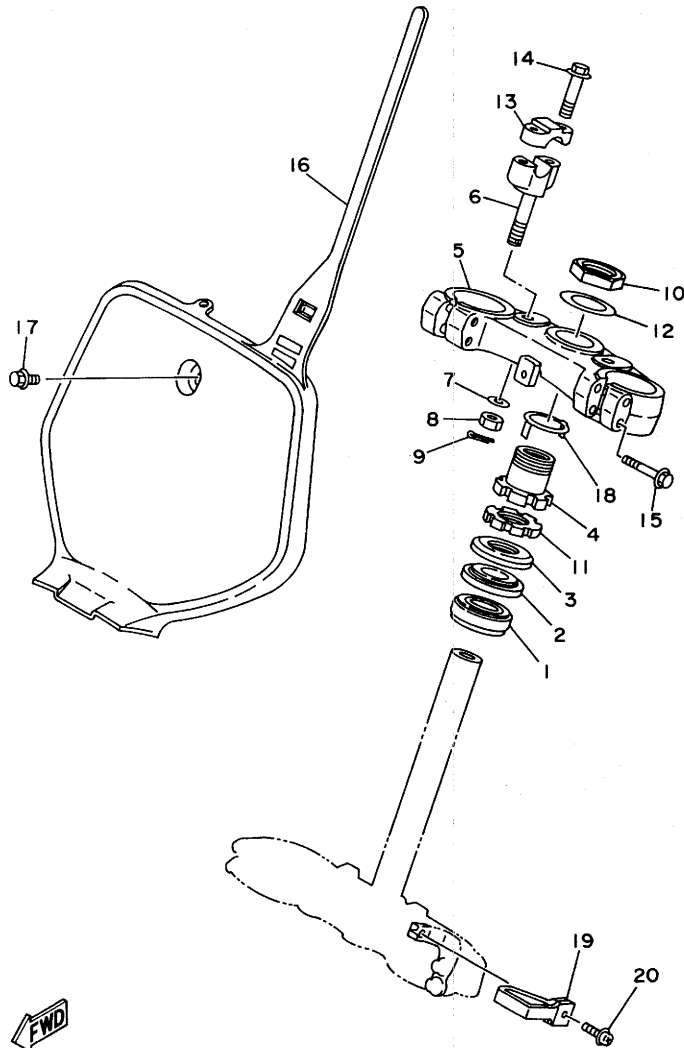

REF. NO.	PART NO.	DESCRIPTION	Q'TY	REMARKS
1	93332-00067	BEARING	1	
2	93332-00068	BEARING	1	
3	2HG-23416-00	COVER, ball race 2	1	
4	90179-28603	NUT	1	
5	4DB-23435-00	CROWN, handle	1	
6	3SR-23442-00	HOLDER, handle lower	2	
7	92990-12200	WASHER, plain	2	
8	95611-12100	NUT, u	2	
9	91401-25020	PIN, cotter	2	
10	90170-36394	NUT	1	
11	90179-28602	NUT	1	
12	90201-365M5	WASHER, plate	1	
13	3SP-23441-00	HOLDER, handle upper	2	
14	95023-08035	BOLT	4	
15	95021-08040	BOLT, flange	4	
16	4DA-23485-00	PLATE, number	1	
17	90119-06185	BOLT, with washer	1	
18	3SP-23418-00	WASHER, special	1	
19	4DA-23389-00	GUIDE, cable	1	
20	90159-05122	SCREW, with washer	1	



4DB2100-2210

C15

FIG. 22 FRONT FORK

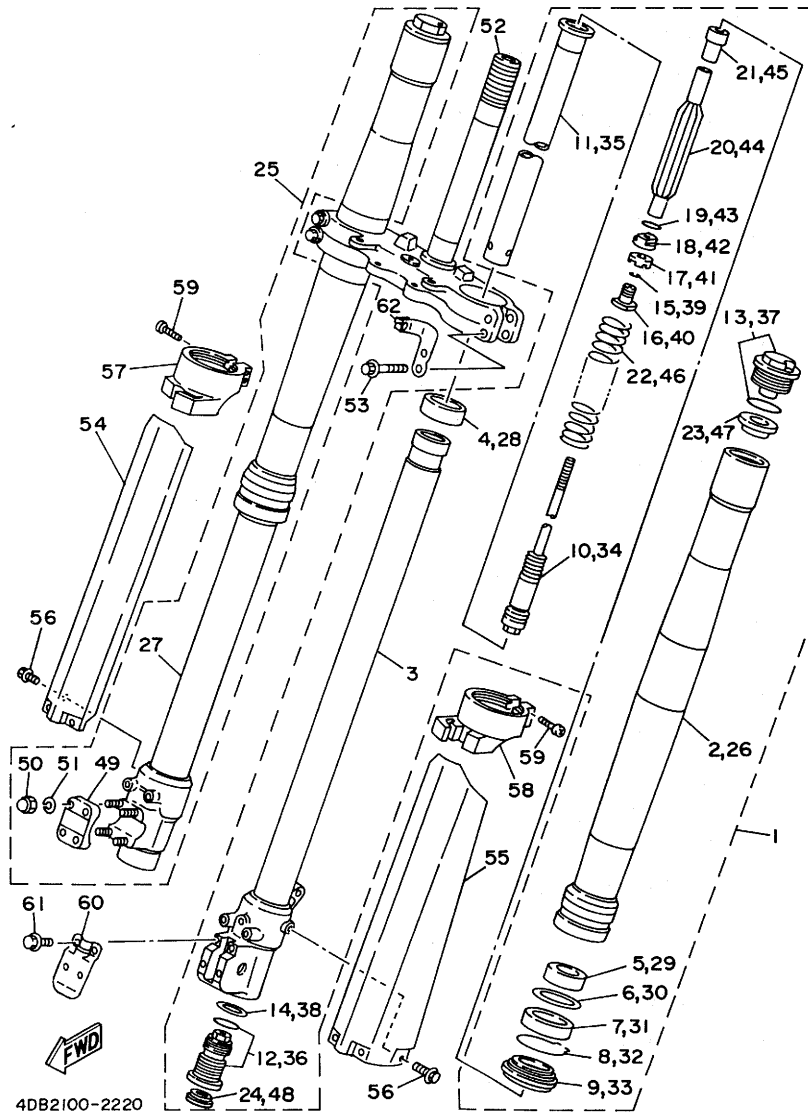

4DB2100-2220

REF. NO.	PART NO.	DESCRIPTION	Q'TY	REMARKS
1	4DB-23102-L0	FRONT FORK ASSY (L.H)	1	UR
	4DB-23102-M0	FRONT FORK ASSY (L.H)	1	UR FOR EUROPE, JAPAN
2	4DA-23136-L0	.TUBE, outer 2	1	
3	4DA-23120-L0	.INNER TUBE COMP. 2	1	
4	3XJ-23171-L0	.PISTON, front fork	1	
5	3XJ-23125-L0	.METAL, slide 1	1	
6	4V4-23146-L0	.WASHER, oil seal	1	
7	3XJ-23145-L0	.OIL SEAL	1	
8	4V4-23153-L0	.RING, snap	1	
9	3XJ-23144-L0	.SEAL, dust	1	
10	4DA-2314A-L0	.PISTON ROD ASSY	1	
11	4DA-23170-L0	.CYLINDER COMP., front fork	1	
12	4DB-2316A-L0	.VALVE COMP.	1	UR
	4DB-2316A-M0	.VALVE COMP.	1	UR FOR EUROPE, JAPAN
13	4DA-23111-L0	.BOLT, cap	1	
14	2HH-23158-L0	.GASKET	1	
15	3XJ-23153-L0	.RING, snap	2	
16	3XJ-23113-L0	.COLLAR	1	
17	3XJ-23166-L0	.SPACER, oil lock	1	
18	3XJ-23778-L0	.NUT	1	
19	36Y-23147-10	.O-RING	1	
20	3XJ-23142-L0	.SEAT, spring upper	1	
21	4DA-23778-L0	.NUT	1	
22	4DB-23141-L0	.SPRING, front fork (K=0.365)	1	
23	3XJ-23143-L0	.SEAT, spring lower	1	
24	3JD-2312G-L0	.PLUG	1	
25	4DB-23103-L0	FRONT FORK ASSY (R.H)	1	UR
	4DB-23103-M0	FRONT FORK ASSY (R.H)	1	UR FOR EUROPE, JAPAN

D2

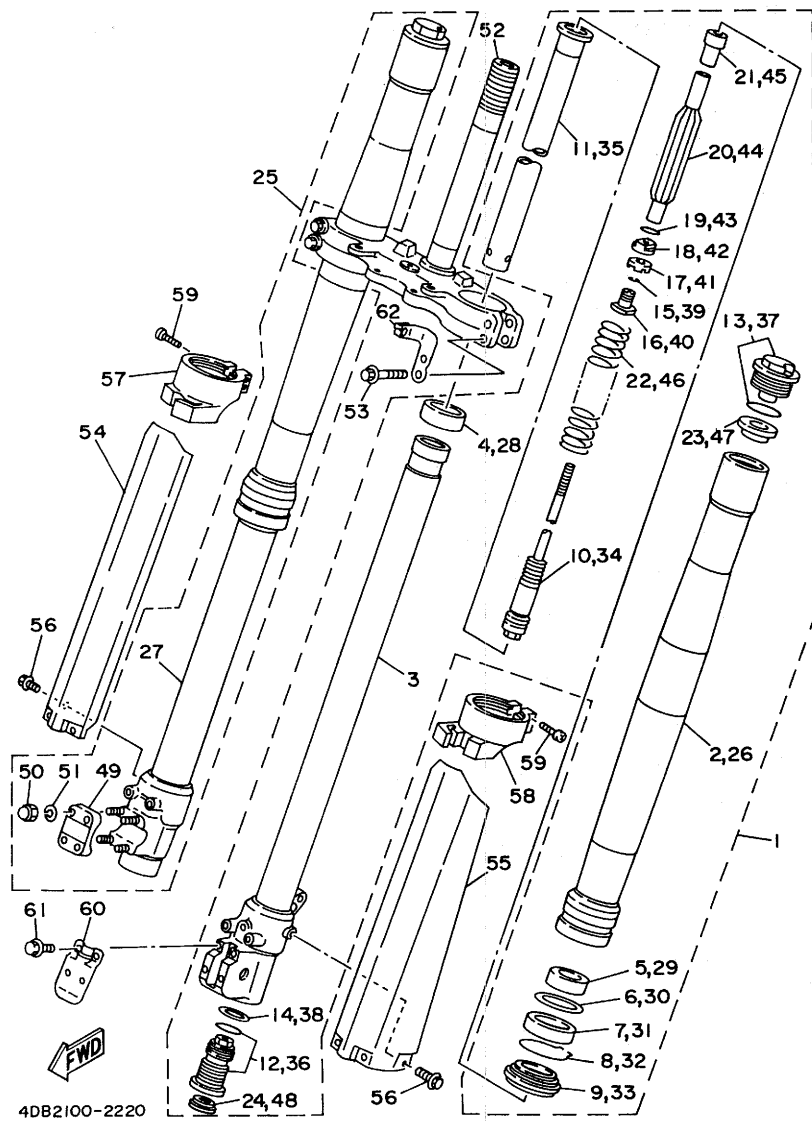

4DB2100-2220

FIG. 22 FRONT FORK

REF. NO.	PART NO.	DESCRIPTION	Q'TY	REMARKS
26	4DA-23136-L0	.TUBE, outer 2	1	
27	4DA-23110-L0	.INNER TUBE COMP. 1	1	
28	3XJ-23171-L0	.PISTON, front fork	1	
29	3XJ-23125-L0	.METAL, slide 1	1	
30	4V4-23146-L0	.WASHER, oil seal	1	
31	3XJ-23145-L0	.OIL SEAL	1	
32	4V4-23153-L0	.RING, snap	1	
33	3XJ-23144-L0	.SEAL, dust	1	
34	4DA-2314A-L0	.PISTON ROD ASSY	1	
35	4DA-23170-L0	.CYLINDER COMP., front fork	1	
36	4DB-2316A-L0	.VALVE COMP.	1	UR
	4DB-2316A-M0	.VALVE COMP.	1	UR FOR EUROPE, JAPAN
37	4DA-23111-L0	.BOLT, cap	1	
38	2HH-23158-L0	.GASKET	1	
39	3XJ-23153-L0	.RING, snap	2	
40	3XJ-23113-L0	.COLLAR	1	
41	3XJ-23166-L0	.SPACER, oil lock	1	
42	3XJ-23778-L0	.NUT	1	
43	36Y-23147-10	.O-RING	1	
44	3XJ-23142-L0	.SEAT, spring upper	1	
45	4DA-23778-L0	.NUT	1	
46	4DB-23141-L0	.SPRING, front fork (K=0.365)	1	
47	3XJ-23143-L0	.SEAT, spring lower	1	
48	3JD-23126-L0	.PLUG	1	
49	4DA-23167-L0	.HOLDER, axle	1	
50	5Y3-23393-00	.NUT, special	4	
51	92990-06100	.WASHER, spring	4	
52	4DA-23340-L0	UNDER BRACKET COMP.	1	

D3

FIG. 22 FRONT FORK

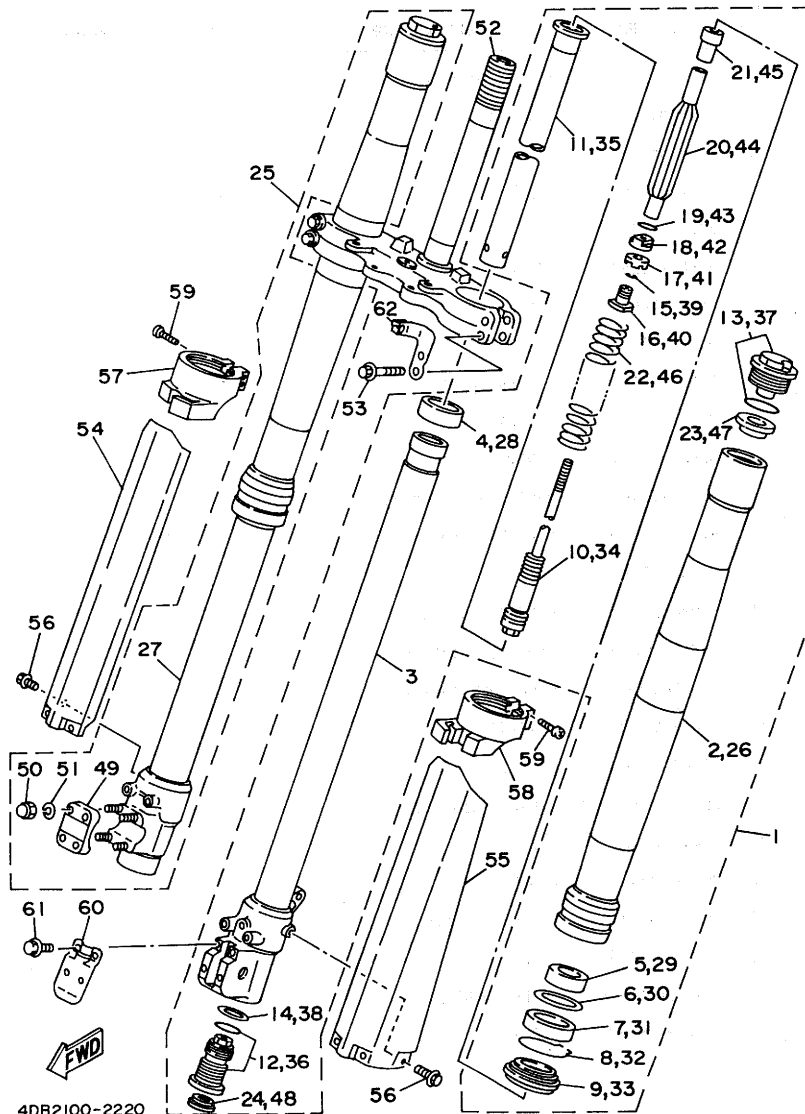

REF. NO.	PART NO.	DESCRIPTION	Q'TY	REMARKS
53	95021-08040	BOLT, flange	4	
54	4DA-2314J-L0	PROTECTOR COMP., 2	1	
55	4DA-2314H-L0	PROTECTOR COMP., 1	1	
56	3SP-23356-L0	BOLT 2	6	
57	4DA-2314G-L0	PROTECTOR GUIDE COMP., 2	1	
58	4DA-2314F-L0	PROTECTOR GUIDE COMP., 1	1	
59	98501-04030	SCREW, pan head	4	
60	3SP-2314E-L0	COVER, hose	1	
61	3SP-23346-L0	BOLT 1	4	
62	4DA-2331E-L0	GUIDE, cable	1	

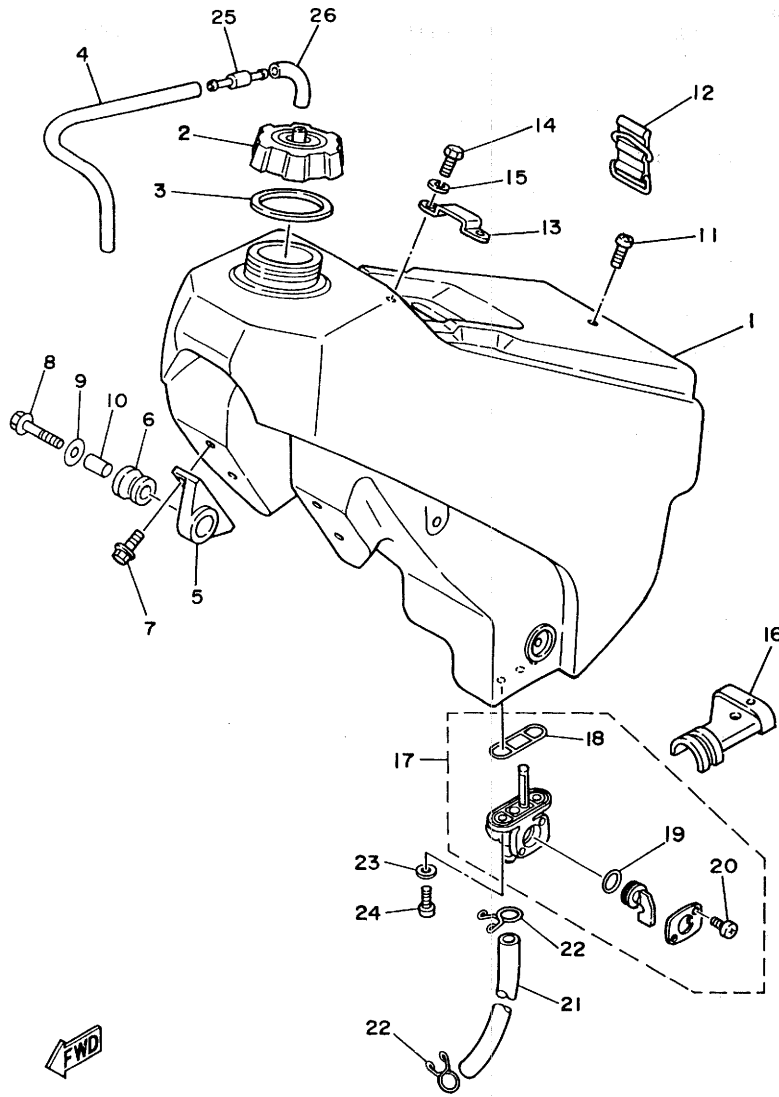

FIG. 23 FUEL TANK

REF. NO.	PART NO.	DESCRIPTION	Q'TY	REMARKS
1	3XJ-24110-00	FUEL TANK COMP.	1	
2	5X7-24611-01	BODY, cap	1	
3	5X7-24612-00	GASKET, cap	1	
4	90445-09100	HOSE	1	
5	24X-24144-00	HOLDER, damper	2	
6	90480-18549	GROMMET	2	
7	95023-06016	BOLT	4	
8	95023-06035	BOLT	2	
9	90201-06697	WASHER, plate	2	
10	90387-06027	COLLAR	2	
11	98980-06020	SCREW, bind	1	
12	3SP-24173-00	BAND, tank fitting 1	1	
13	5X6-2412F-00	BRACKET, seat	1	
14	97003-06012	BOLT	2	
15	92990-06100	WASHER, spring	2	
16	1LX-24181-00	DAMPER, locating 1	1	
17	3JD-24500-01	FUEL COCK ASSY 1	1	
18	4X8-24512-00	.O-RING	1	
19	3AJ-24534-00	.SEAL, cock	1	
20	98503-03008	.SCREW, pan head	2	
21	90445-11452	HOSE	1	
22	90467-10008	CLIPP	2	
23	90202-05193	WASHER, plate	2	
24	90149-06011	SCREW	2	
25	3XJ-24380-00	PIPE JOINT ASSY	1	
26	90445-09058	HOSE	1	

FWD
4DB2100-2230

D5

FIG. 24 SEAT

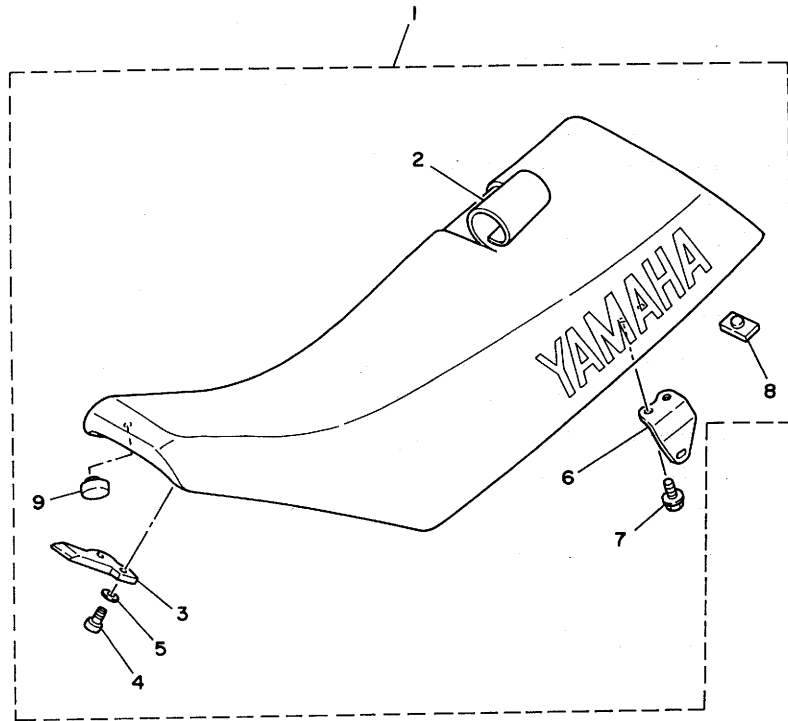

REF. NO.	PART NO.	DESCRIPTION	Q'TY	REMARKS
1	3XJ-24770-00	SEMI-DOUBLE SEAT ASSY	1	UR
	3XJ-24770-10	SEMI-DOUBLE SEAT ASSY	1	UR FOR JAPAN
2	3XJ-24731-00	.COVER, seat	1	UR
	3XJ-24731-10	.COVER, seat	1	UR FOR JAPAN
3	5X6-24748-10	.BRACKET, seat	1	
4	98501-06012	.SCREW, pan head	2	
5	92901-06600	.WASHER, plate	2	
6	1LX-24738-01	.BRACKET, seat	2	
7	95023-06012	.BOLT	4	
8	509-24724-00	.DAMPER, seat	1	
9	3L7-24724-00	.DAMPER, seat	2	



3XJ1100-1240

D6

FIG. 25 FRONT WHEEL

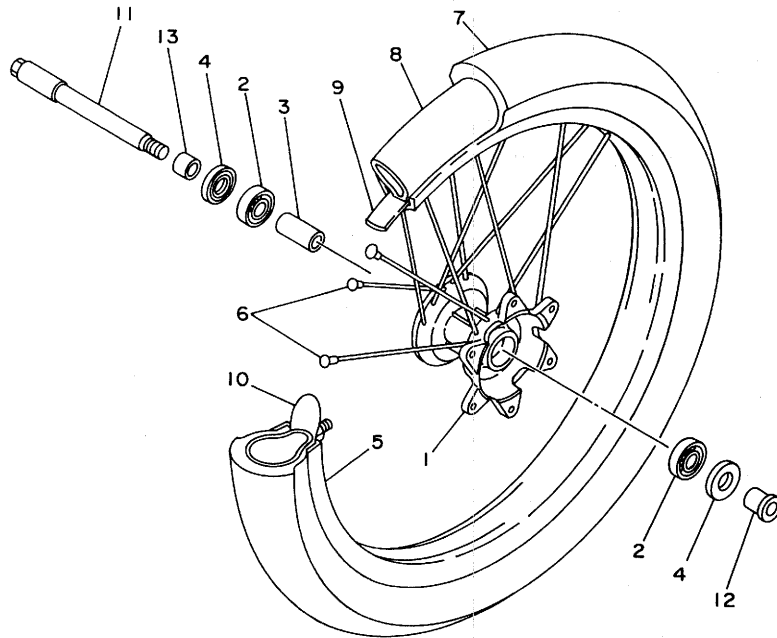

REF. NO.	PART NO.	DESCRIPTION	Q'TY	REMARKS
1	4DA-25111-00	HUB, front	1	
2	93306-00316	BEARING	2	
3	90560-17379	SPACER	1	
4	93102-22445	OIL SEAL	2	
5	94416-21499	RIM (1.60-21)	1	
6	4DA-25104-00	SPOKE SET, front	1	
7	94108-217X6	TIRE (80/100-21-M61)	1	UR BRIDGESTONE
	94108-219U5	TIRE (80/100-21 K990)	1	UR DUNLOP FOR EUROPE
8	94209-21277	TUBE (MCS 90/90-21 TR-4)	1	UR BRIDGESTONE
	94227-21123	TUBE (2.75-21)	1	UR BRIDGESTONE FOR EUROPE
9	94330-21084	BAND, rim (3.00-21)	1	UR BRIDGESTONE
	94307-21145	BAND, rim (70-80/100-21)	1	UR DUNLOP FOR EUROPE
10	5X2-25394-00	SPACER, bead	1	
11	4DA-25181-00	AXLE, wheel	1	
12	90387-173Y0	COLLAR	1	
13	90387-172Y9	COLLAR	1	



4DB2100-2250

D7

FIG. 26 FRONT BRAKE CALIPER

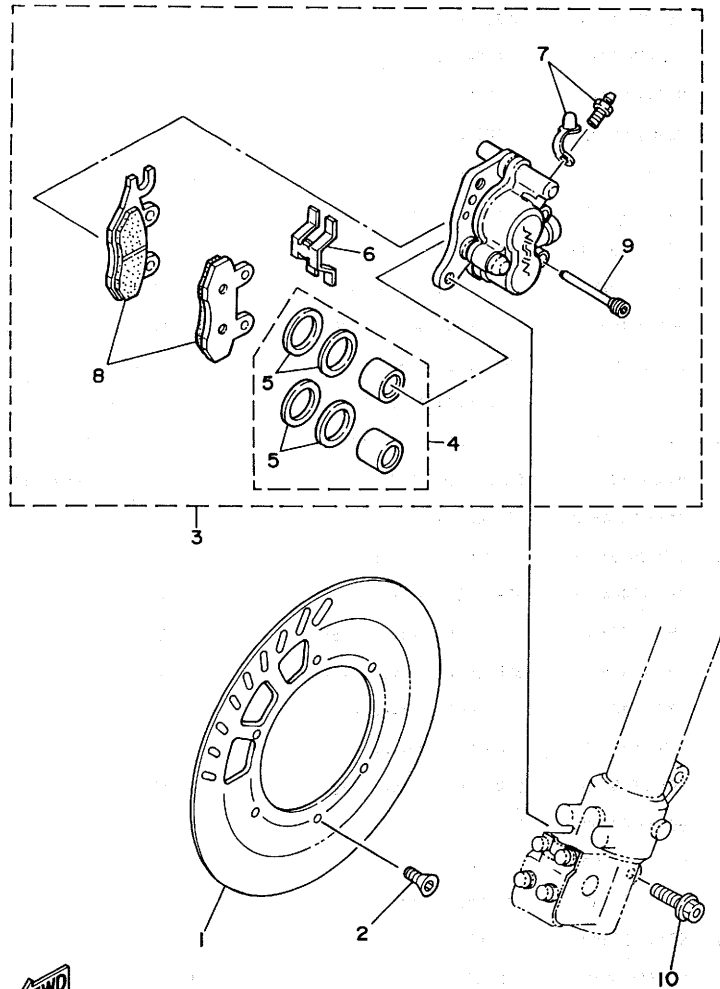

REF. NO.	PART NO.	DESCRIPTION	Q'TY	REMARKS
1	4DA-2582T-00	DISC, brake	1	
2	90149-06272	SCREW	6	
3	3SP-2580T-00	CALIPER ASSY (LEFT)	1	
4	3JD-W0057-00	.PISTON ASSY, caliper	1	
5	3JD-W0047-00	..CALIPER SEAL KIT	1	
6	3JD-25919-00	.SUPPORT, pad	1	
7	1UY-W0048-50	.BLEED SCREW KIT	1	
8	3SP-W0045-00	.BRAKE PAD KIT	1	
9	3GD-25933-00	.PIN, pad	2	
10	90105-08659	BOLT, washer based	2	



4DB2100-2260

D8

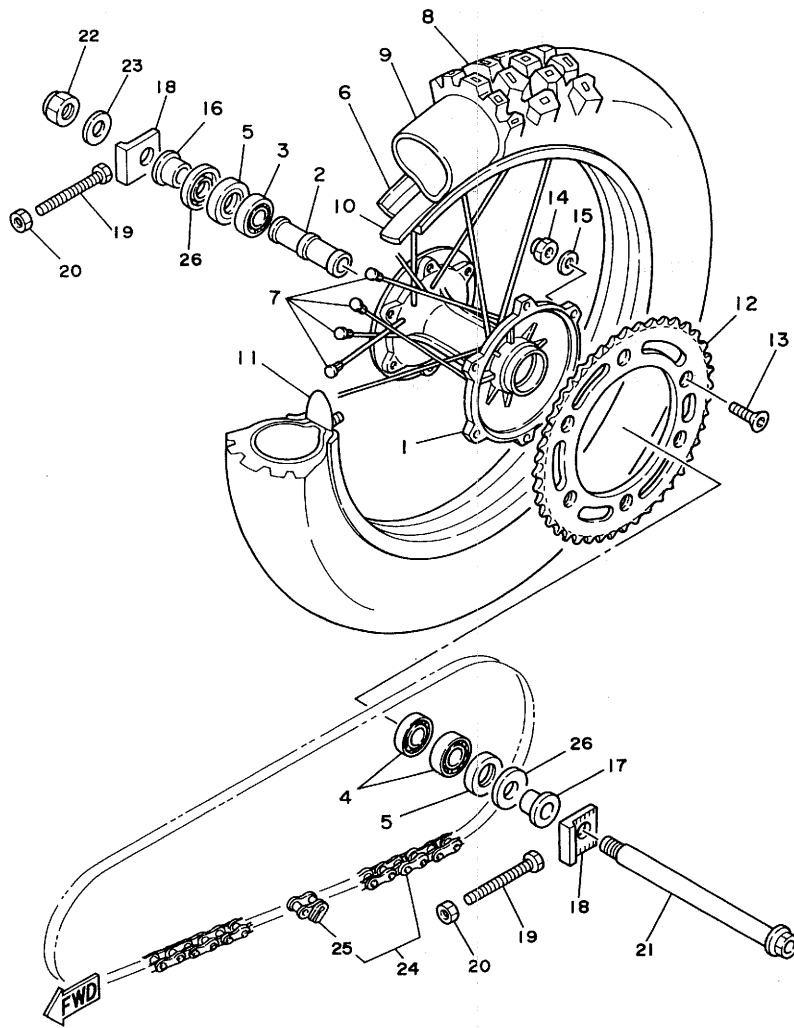

3XJ1100-1270

FIG. 27 REAR WHEEL

REF. NO.	PART NO.	DESCRIPTION	Q'TY	REMARKS
1	3SP-25311-00	HUB, rear	1	
2	3JD-25317-01	SPACER, bearing	1	
3	93306-00418	BEARING	1	
4	93306-00438	BEARING	2	
5	93106-28023	OIL SEAL	2	
6	94418-19485	RIM (1.85-19)	1	
7	3JD-25304-00	SPOKE SET, rear	1	
8	94110-197X7	TIRE (100/90-19-M62)	1	UR BRIDGESTONE
	94110-199U4	TIRE (100/90-19 K990)	1	UR DUNLOP FOR EUROPE
9	94210-19222	TUBE (3.25-19)	1	UR BRIDGESTONE
	94210-19224	TUBE (100/90-19 TR4 BTL)	1	UR DUNLOP FOR EUROPE
10	94316-19156	BAND, rim (1.85-19)	1	UR BRIDGESTONE
	94327-19111	BAND, rim (2.75-19)	1	UR INOUE FOR EUROPE
11	2X3-25394-00	SPACER, bead	2	
12	3JD-25451-01	SPROCKET, driven (51T)	1	STD
	39W-25444-01	SPROCKET, driven (44T)	1	AP
	39W-25445-01	SPROCKET, driven (45T)	1	AP
	39W-25446-01	SPROCKET, driven (46T)	1	AP
	39W-25448-00	SPROCKET, driven (48T)	1	AP
	39W-25450-00	SPROCKET, driven (50T)	1	AP
	39W-25452-01	SPROCKET, driven (52T)	1	AP
13	90109-08792	BOLT	6	
14	95611-08100	NUT, u	6	
15	90201-081A6	WASHER, plate	6	
16	90387-203V0	COLLAR	1	
17	90387-200Y5	COLLAR	1	
18	3SP-25388-00	PULLER, chain 1	2	
19	90101-08699	BOLT	2	

D9

FIG. 27 REAR WHEEL

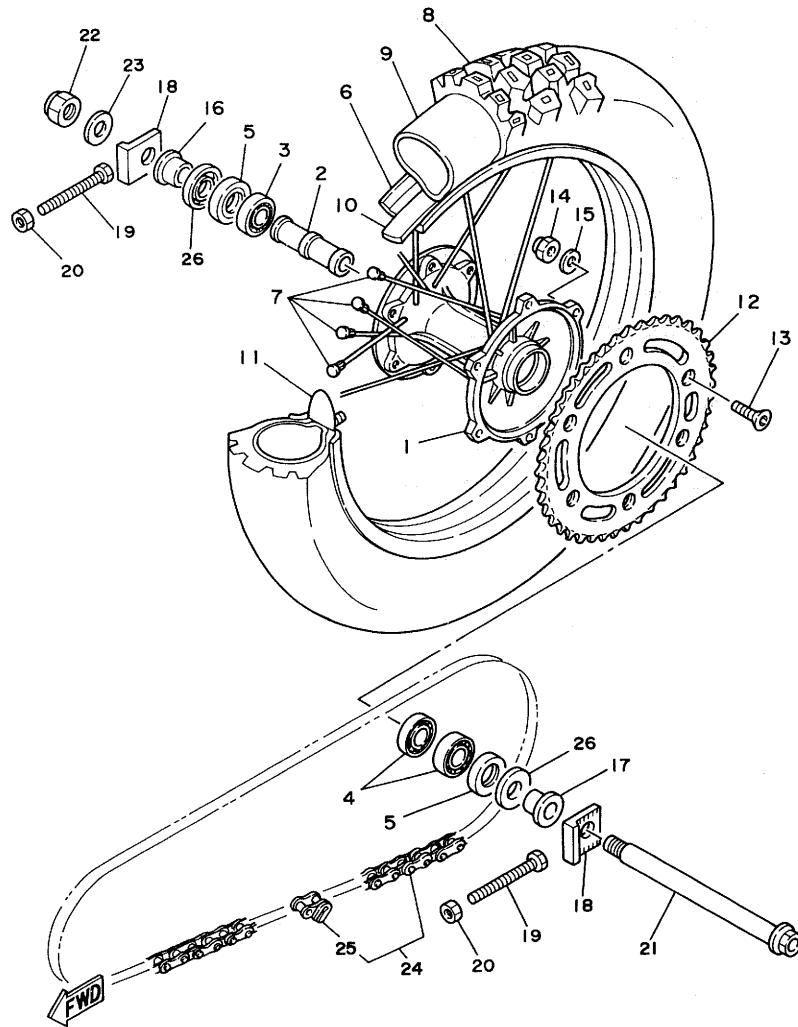

REF. NO.	PART NO.	DESCRIPTION	Q'TY	REMARKS
20	95701-08500	NUT, flange	2	
21	3JD-25381-01	AXLE, wheel	1	
22	90185-18104	NUT, self-locking	1	
23	92990-18600	WASHER	1	
24	94581-13116	CHAIN	1	
25	94681-13001	.JOINT, chain	1	
26	4V4-25367-00	COVER, hub dust	2	

3XJ1100-1270

FIG. 28 REAR BRAKE CALIPER

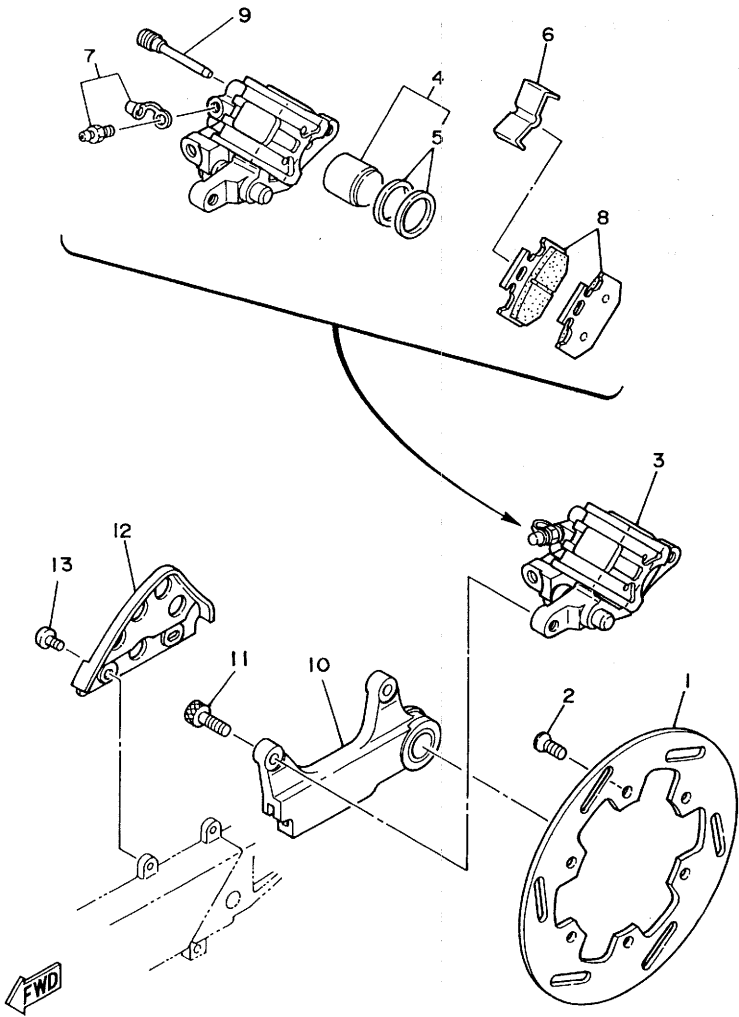

REF. NO.	PART NO.	DESCRIPTION	Q'TY	REMARKS
1	4DA-2582W-00	DISC, rear brake 2	1	
2	90149-06272	SCREW	6	
3	4DA-2580W-00	CALIPER ASSY, rear 2	1	
4	3SP-W0057-50	.PISTON ASSY, caliper	1	
5	3JD-W0047-50	..CALIPER SEAL KIT	1	
6	3SP-25919-51	.SUPPORT, pad	1	
7	1UY-W0048-50	.BREED SCREW KIT	1	
8	4DA-W0046-00	.BRAKE PAD KIT, 2	1	
9	3SP-25924-51	.PIN, pad	2	
10	3XJ-25920-00	SUPT. BRKT. ASSY	1	
11	91311-08025	BOLT	2	
12	3JD-27491-00	PROTECTOR	1	
13	92011-06012	BOLT, button head	2	

4DB2100-2280

D11

FIG. 29 STEERING HANDLE. CABLE

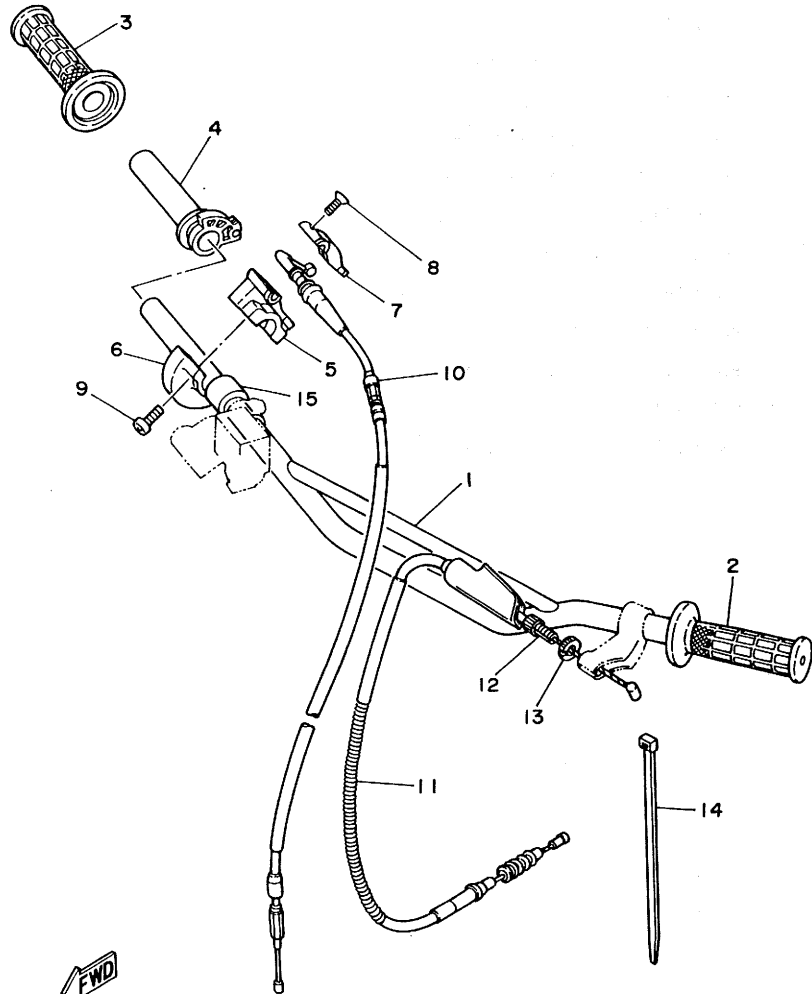

REF. NO.	PART NO.	DESCRIPTION	Q'TY	REMARKS
1	3XJ-26111-00	HANDLEBAR	1	
2	1LX-26241-01	GRIP (LEFT)	1	
3	1LX-26242-01	GRIP (RIGHT)	1	
4	23X-26243-00	TUBE, throttle guide	1	
5	23X-26281-00	CAP, grip upper	1	
6	431-26282-02	CAP, grip lower	1	
7	5X2-2628H-01	CAP, wire	1	
8	98706-04012	SCREW, flat head	2	
9	98506-05016	SCREW, pan head	2	
10	3JD-26311-01	CABLE, throttle 1	1	
11	3XJ-26335-00	CABLE, clutch	1	
12	90123-08090	BOLT	1	
13	90179-08401	NUT	1	
14	90464-14117	CLAMP	1	
15	90560-22281	SPACER	1	

 4DB2100-2290

D12

FIG. 30 FRONT MASTER CYLINDER

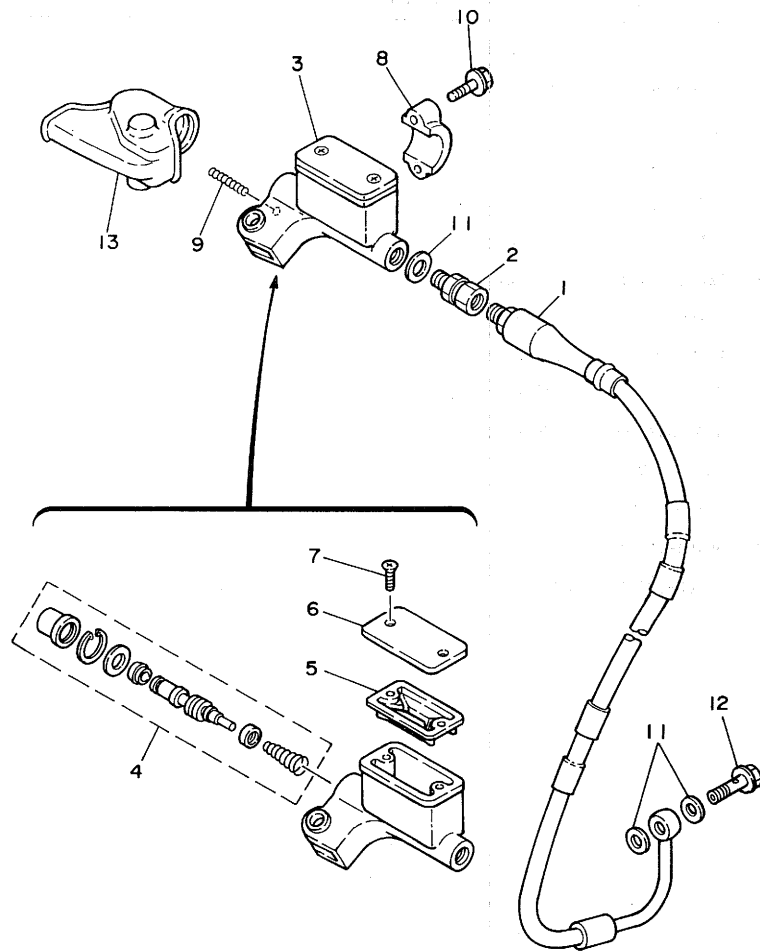

REF. NO.	PART NO.	DESCRIPTION	Q'TY	REMARKS
1	4DA-25872-00	HOSE, brake 1	1	
2	3LC-25885-00	JOINT	1	
3	3SP-25870-00	MASTER CYLINDER SUB ASSY	1	
4	3SP-W0041-00	.CYLINDER KIT, master	1	
5	56A-25854-00	.DIAPHRAGM, reservoir	1	
6	2VN-25852-00	.CAP, reservoir	1	
7	98706-04012	.SCREW, flat head	2	
8	56A-25867-00	BRACKET, master cylinder	1	
9	90501-061G2	SPRING, compression	1	
10	95026-06025	BOLT, flange	2	
11	90201-10118	WASHER, plate	3	
12	90401-10034	BOLT, union	1	
13	56A-26372-01	COVER, handle lever 1	1	



3SP1100-0300

D13

FIG. 31 STAND. FOOTREST

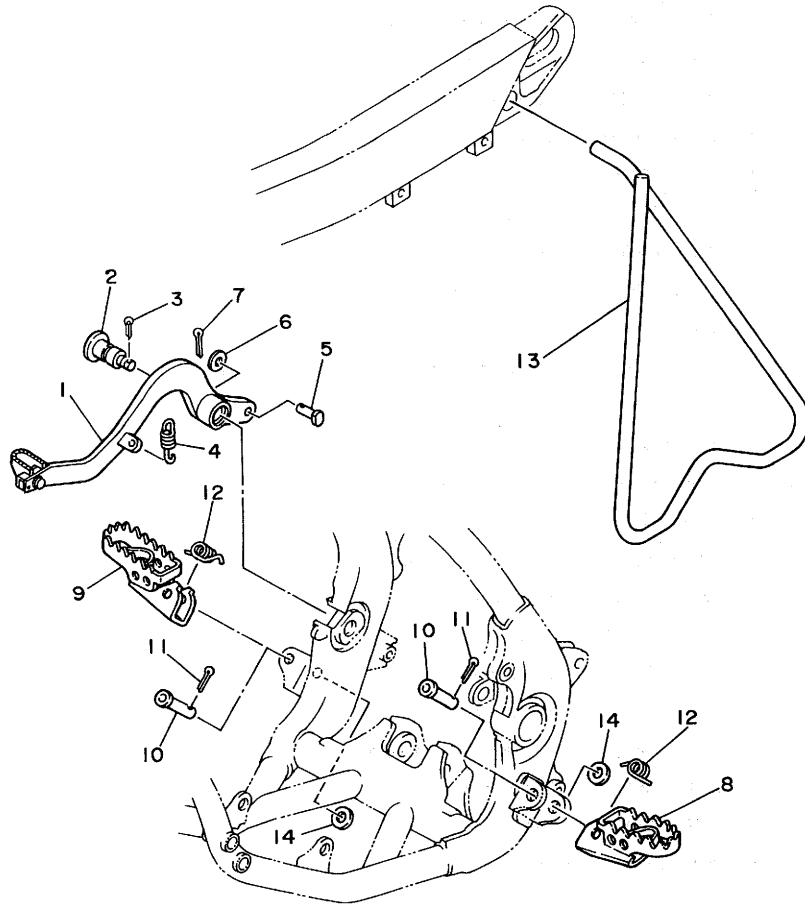

REF. NO.	PART NO.	DESCRIPTION	Q'TY	REMARKS
1	3JD-27200-01	PEDAL, brake	1	
2	4AA-27217-00	BOLT	1	
3	91401-20015	PIN, cotter	1	
4	90506-14410	SPRING, tension	1	
5	90240-08120	PIN, clevis	1	
6	92901-08600	WASHER, plate	1	
7	91401-25020	PIN, cotter	1	
8	4DA-27411-00	FOOTREST 1	1	
9	4DA-27421-00	FOOTREST 2	1	
10	90240-10117	PIN, clevis	2	
11	91401-25020	PIN, cotter	2	
12	90508-28777	SPRING, torsion	2	
13	3SP-27311-00	STAND, side	1	
14	90201-10119	WASHER, plate	2	



3XJ1100-1310

D14

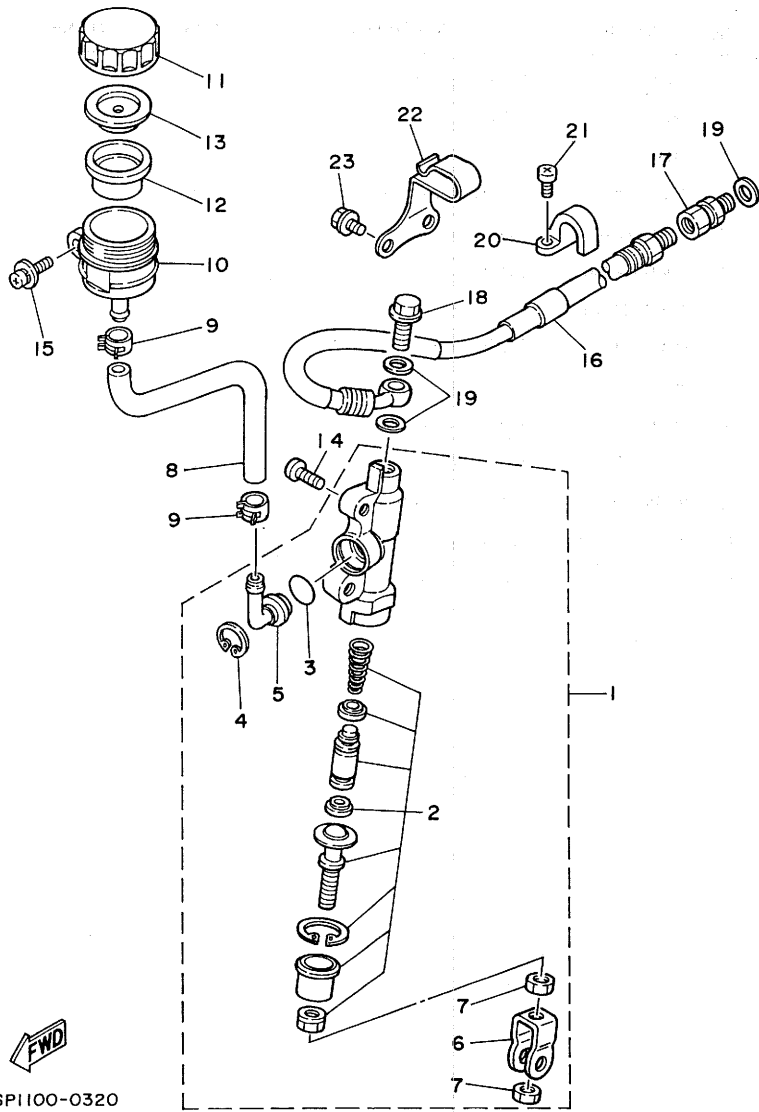

3SPI100-0320

FIG. 32 REAR MASTER CYLINDER

REF. NO.	PART NO.	DESCRIPTION	Q'TY	REMARKS
1	3SP-2583V-00	RR. MASTER CYLINDER ASSY	1	
2	1FK-W0042-50	.CYLINDER KIT, master	1	
3	93210-15620	.O-RING	1	
4	2VN-25866-00	.CIRCLIP	1	
5	2VN-2582A-50	.JOINT	1	
6	3SP-27222-00	.JOINT	1	
7	95303-08600	.NUT	2	
8	3JD-25895-00	HOSE, reservoir	1	
9	90467-11044	CLIP	2	
10	2VN-25894-00	TANK, reservoir	1	
11	3XP-25852-50	CAP, reservoir	1	
12	2VN-25854-00	DIAPHRAGM, reservoir	1	
13	2VN-25855-00	BUSH, diaphragm	1	
14	92013-06016	BOLT	2	
15	90159-06056	SCREW, with washer	1	
16	3SP-25873-00	HOSE, brake 2	1	
17	3LC-25885-00	JOINT	1	
18	90401-10034	BOLT, union	1	
19	90201-10118	WASHER, plate	3	
20	2VM-25876-00	HOLDER, brake hose 2	1	
21	97780-50510	SCREW, tapping	2	
22	90462-12195	CLAMP	1	
23	95023-06008	BOLT	2	

D15

FIG. 33 GENERATOR

REF. NO.	PART NO.	DESCRIPTION	Q'TY	REMARKS
1	4DB-85510-00	STATOR ASSY	1	
2	4DB-85550-00	ROTOR ASSY	1	
3	90149-06011	SCREW	2	
4	95311-10600	NUT	1	
5	90201-10774	WASHER, plate	1	

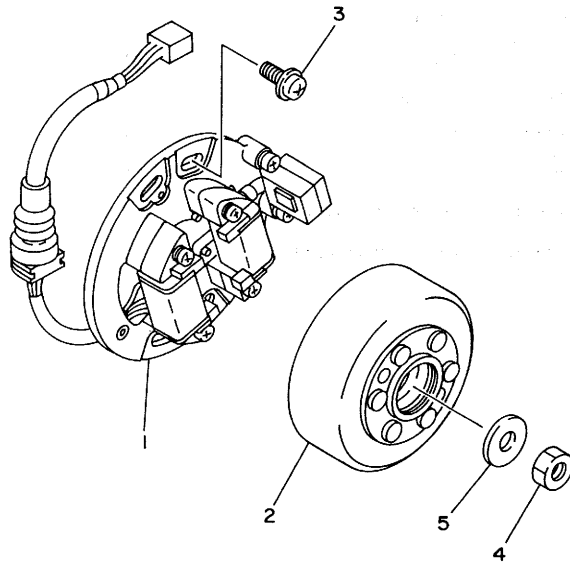

4DB2100-2330

E2

FIG. 34 HANDLE SWITCH. LEVER

REF. NO.	PART NO.	DESCRIPTION	Q'TY	REMARKS
1	38V-82911-00	HOLDER, lever 1	1	
2	38V-82913-00	HOLDER, lever lower 1	1	
3	23X-83912-00	LEVER 1	1	
4	90109-06799	BOLT	1	
5	95616-06100	NUT, u	1	
6	97006-05016	BOLT	2	
7	3SP-83922-00	LEVER 2	1	
8	90109-06577	BOLT	1	
9	95616-06100	NUT, u	1	
10	90149-06153	SCREW	1	
11	90170-06010	NUT	1	
12	23X-83976-00	SWITCH, handle 1	1	
13	437-83936-01	BAND, switch cord	2	

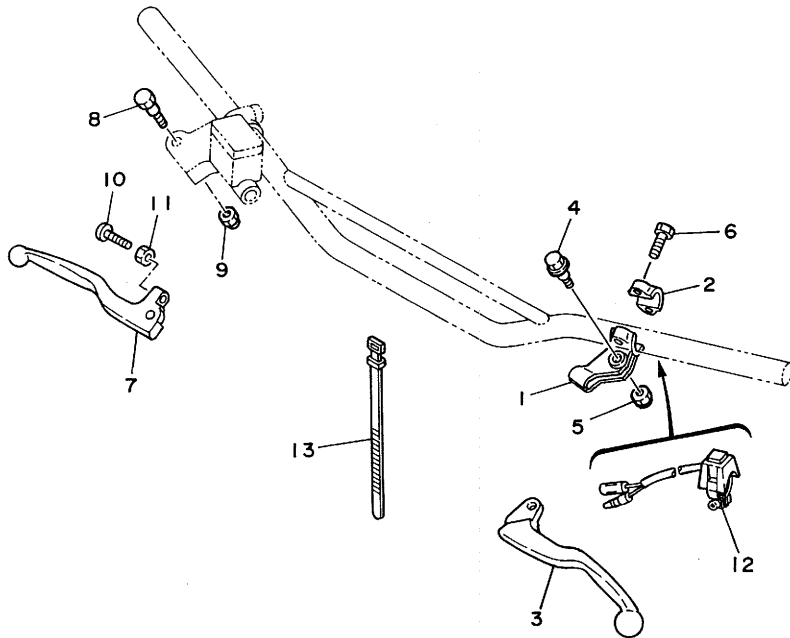

3SP1100-0340

E3

FIG. 35 ELECTRICAL 1

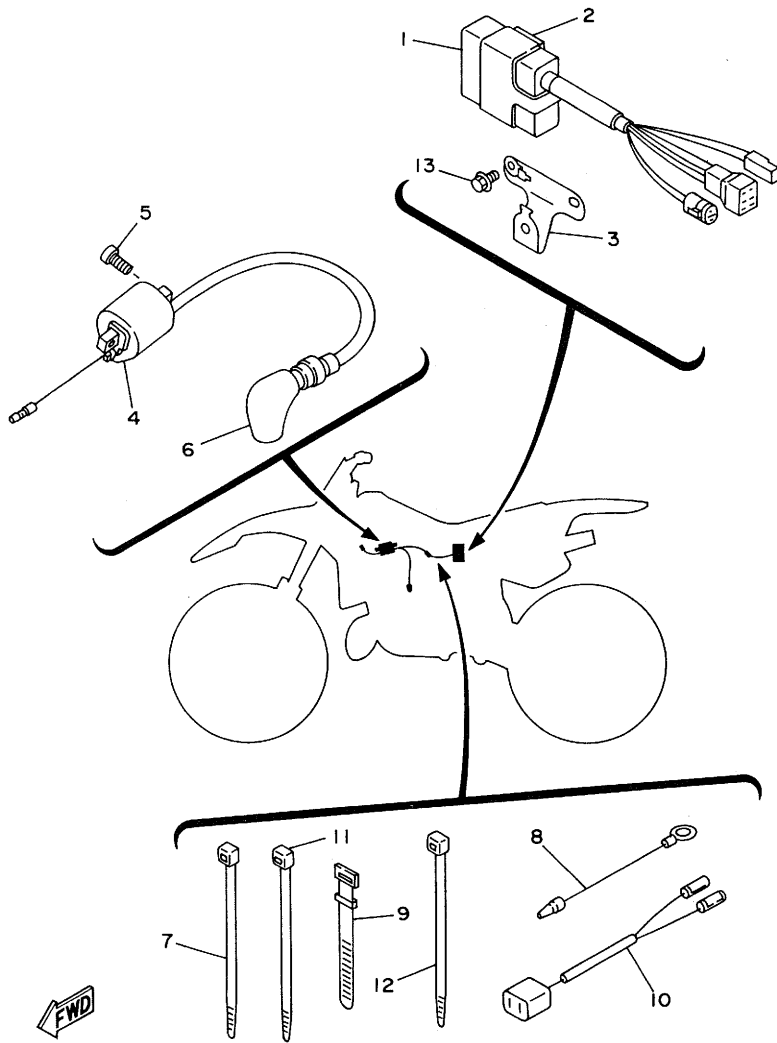

REF. NO.	PART NO.	DESCRIPTION	Q'TY	REMARKS
1	4DB-85540-00	C.D.I. UNIT ASSY	1	
2	4DB-85546-00	BAND	1	
3	4DB-85991-00	BRACKET, unit	1	
4	3SR-82310-10	IGNITION COIL ASSY	1	
5	97021-06016	BOLT	2	
6	2TV-82370-00	PLUG CAP ASSY	1	WITH NOISE SUPPRESSOR
7	12R-82591-00	BAND	2	
8	1VJ-82519-00	WIRE, earth lead	1	
9	25G-83936-01	BAND, switch cord	1	
10	4DB-82519-00	WIRE, earth lead	1	
11	12R-82591-00	BAND	2	
12	1UA-82591-00	BAND	2	
13	90105-06553	BOLT, washer based	2	

4DB2100-2350

E4

ALTERNATE PARTS

FIG. 36 ALTERNATE (CHASSIS)

REF. NO.	PART NO.	DESCRIPTION	Q'TY	REMARKS
1	3XJ-22212-81	SPRING (K=4.4)	1	AP (SOFT)
	3XJ-22212-01	SPRING (K=4.6)	1	AP (SOFT) FOR EUROPE
	3XJ-22212-11	SPRING (K=4.8)	1	AP (HARD)
	4DA-22212-20	SPRING (K=5.0)	1	AP (HARD) FOR EUROPE
2	4DA-23141-10	SPRING, front fork (K=0.350)	2	AP (SOFT)
	4DA-23141-30	SPRING, front fork (K=0.380)	2	AP (HARD)
3	4DA-23364-L0	COLLAR 2	1	UN

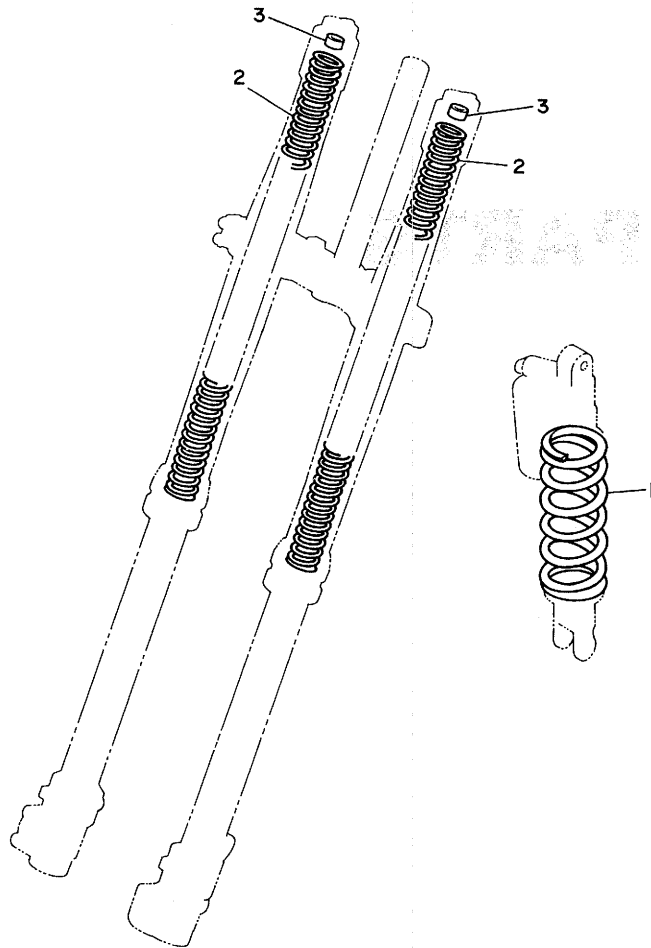

3XJ1100-1360

E5

REPAIR KIT

33

FIG. 37 REPAIR KIT

REF. NO.	PART NO.	DESCRIPTION	Q'TY	REMARKS
1	4DB-11630-00	PISTON ASSY (STD)	1	
2	4DB-11631-00-B0	.PISTON (STD)	1	
3	5X4-11611-01	.RING, piston	1	
4	137-11633-00	.PIN, piston	1	
5	93450-17129	.CIRCLIP	2	
6	3JD-11650-00	CONNECTING ROD ASSY	1	
7	2HG-11651-00	.ROD, connecting	1	
8	3JD-11681-00	.PIN, crank 1	1	
9	90209-22257	.WASHER	2	
10	93310-522M4	.BEARING, cylindrical	1	
11	93310-216L2	.BEARING, cylindrical	1	

REPAIR KIT

E6

INDEX

[10]

NUMERICAL INDEX

PART NO.	GRID NO.	PART NO.	GRID NO.	PART NO.	GRID NO.	PART NO.	GRID NO.	PART NO.	GRID NO.	PART NO.	GRID NO.
3SP-W0041-00	D-13	1LX-11995-01	B- 3	3JE-14185-00	B- 9	3JD-16340-00	B-15	3XJ-21721-01	C-10	4DB-23102-L0	D- 2
1FK-W0042-50	D-15	1LX-1240A-00	B- 7	353-14186-00	B- 9	3XJ-16351-00	B-15	4DB-2173E-00	C-10	4DB-23102-M0	D- 2
3SP-W0045-00	D- 8	3JD-1240A-00	B- 7	363-14187-00	B- 9	3XJ-16356-00	B-15	4DB-2173F-00	C-10	4DB-23103-L0	D- 2
4DA-W0046-00	D-11	2VN-12422-01	B- 6	3JD-14194-00	B- 9	3XJ-16371-00	B-15	3XJ-21731-01	C-10	4DB-23103-M0	D- 2
3JD-W0047-00	D- 8	1LX-12428-01	B- 6	55X-14196-00	B- 9	4DB-16382-00	B-15	3XJ-2174A-00	C-10	4DA-23110-L0	D- 3
3JD-W0047-50	D-11	1LX-12450-00	B- 6	2HH-14197-00	B- 9	3SR-17121-00	C- 3	3JD-2174F-00	C-11	4DA-23111-L0	D- 2
1UY-W0048-50	D- 8	3JD-12459-00	B- 6	3XJ-1441A-00	B- 8	3SR-17131-00	C- 3	3XJ-21741-01	C-10		D- 3
	D-11	22W-12462-00	B- 7	3JD-14451-00	B- 8	3JD-17151-00	C- 3	3JD-21748-00	C- 9	3XJ-23113-L0	D- 2
3JD-W0057-00	D- 8	24X-12469-00	B- 7	3XJ-14453-01	B- 8	3JD-17161-00	C- 3	22W-21791-00	C-11		D- 3
3SP-W0057-50	D-11	3JD-12476-00	B- 7	3JD-14458-00	B- 8	1LX-17211-01	C- 3	3XJ-22110-01	C-12	3JD-2312G-L0	D- 2
4DB-W1132-00	B- 2	1LU-1248A-01	B- 7	3JD-14459-00	B- 8	3XJ-17221-00	C- 3	156-22127-00	C-12		D- 3
3XJ-W1441-01	B- 8	3JD-12481-01	B- 7	3JD-14462-00	B- 8	3SR-17231-00	C- 3	3JD-22128-00	C-12	4DA-23120-L0	D- 2
4DB-11111-00	B- 2	3JD-12482-00	B- 7	3JD-14477-00	B- 8	1LX-17241-00	C- 3	3R4-22129-00	C-12	3XJ-23125-L0	D- 2
4DB-1131A-00	B- 2	3JD-12483-00	B- 7	3JE-14561-00	B- 9	3JD-17251-00	C- 3	1LX-22141-00	C-12		D- 3
4DB-1131F-00	B- 2	3JD-12485-00	B- 7	4DB-14610-00	B-11	3XJ-17261-00	C- 3	3JD-22147-00	C-12	4DA-23136-L0	D- 2
4DB-1131N-00	B- 2	353-13115-01	B-12	3R3-14613-00	B-11	3XJ-17411-00	C- 3	3JD-22151-00	C-12		D- 3
4DB-11311-00	B- 2	3SR-13565-00	B- 8	3M7-14615-00	B-11	137-17417-00-05	B-14	3JD-22156-00	C-12	4DA-2314A-L0	D- 2
1LX-11351-10	B- 2	2VN-13610-00	B- 8	3XJ-1469A-00	B-11	3XJ-17421-00	C- 3	3XJ-2217A-00	C-12		D- 3
3XJ-11400-00	B- 5	1RX-13613-00	B- 8	3XJ-1469A-10	B-11	3XJ-18101-02	C- 6	3XJ-2217F-00	C-13	3SP-2314E-L0	D- 4
3SR-11412-00	B- 5	2VN-13616-00	B- 8	39X-14747-00	B-11	1LX-18110-02	C- 6	3JD-22178-00	C- 7	4DA-2314F-L0	D- 4
3XJ-11422-00	B- 5	2K7-13621-10	B- 8	3XJ-14753-00	B-11	3XJ-18122-00	C- 6	3JD-22178-10	C- 7	4DA-2314G-L0	D- 4
5X4-11611-01	B- 5	4DB-14101-00	B- 9	3XJ-14753-10	B-11	3XJ-18140-00	C- 5	3XJ-2218A-00	C-13	4DA-2314H-L0	D- 4
	E- 6	4DB-14101-10	B- 9	565-14771-00	B-11	3XJ-18172-00	C- 6	3JD-22199-00	C-12	4DA-2314J-L0	D- 4
4DB-11630-00	E- 6	3JD-14103-00	B-10	256-14919-00	B- 9	3XJ-18173-00	C- 6	4DB-22201-00	C-14	4DA-23141-10	E- 5
4DB-11631-00-A0	B- 5	3JD-14104-00	B-10	4DB-15111-00	B-12	3XK-18177-00	C- 5	4DB-22201-10	C-14	4DA-23141-30	E- 5
4DB-11631-00-B0	B- 5	3JD-14107-35	B-10	1LX-15121-12	B-12	3XJ-18178-00	C- 6	4DB-22201-20	C-14	4DB-23141-L0	D- 2
	E- 6	3JD-14112-50	B-10	3R3-15128-01	B-12	3XJ-18182-00	C- 6	4DB-22201-30	C-14		D- 3
4DB-11631-00-C0	B- 5	3JD-14112-55	B-10	1G8-15362-00	B-13	3XJ-18184-00	C- 6	4DB-22210-00	C-14	3XJ-23142-L0	D- 2
4DB-11631-00-D0	B- 5	3JD-14112-60	B-10	1LX-15383-00	C- 3	3XJ-18185-00	C- 6	4DB-22210-10	C-14		D- 3
137-11633-00	B- 5	4DB-14115-00	B- 9	3XJ-15383-00	C- 3	3JD-18511-01	C- 5	4DB-22210-20	C-14	3XJ-23143-L0	D- 2
	E- 6	3JD-14116-A1	B- 9	4DB-15411-00	B-13	2VN-18512-01	C- 5	4DB-22210-30	C-14		D- 3
3JD-11650-00	E- 6	3JD-14116-A4	B- 9	4DB-15415-00	B-13	1LX-18513-01	C- 5	3XJ-22212-01	C-14	3XJ-23144-L0	D- 2
2HG-11651-00	B- 5	3JD-14116-A5	B- 9	3SR-15421-00	B-13	1LX-18531-00	C- 5		E- 5		D- 3
	E- 6	214-14118-00	B- 9	3JD-15431-00	B-13	1LX-18535-00	C- 5	3XJ-22212-11	C-14	3XJ-23145-L0	D- 2
3JD-11681-00	B- 5	3JD-14131-00	B- 9	4DB-15451-00	B-13	3XJ-18540-01	C- 5		E- 5		D- 3
	E- 6	3H1-14142-17	B- 9	1LX-15462-10	B-13	4DB-21110-00-UJ	C- 7	3XJ-22212-81	E- 5	4V4-23146-L0	D- 2
5X5-11911-01	B- 4	3H1-14142-20	B- 9	3JD-15463-10	B-13	3XK-21123-00-T9	C- 7	4DA-22212-20	E- 5		D- 3
5X5-11912-01	B- 4	3H1-14142-25	B- 9	4DB-15620-00	B-14	1LX-21419-01	C- 7	3SP-22213-00	C-14	36Y-23147-10	D- 2
47X-11915-00	B- 2	3H1-14142-30	B- 9	4DB-15621-00	B-14	1LX-21425-00	C- 7	3JD-22214-00	C-14		D- 3
5X4-11921-02	B- 4	137-14143-62-A1	B-10	1LX-15641-00	B-14	4DA-21511-00	C- 9	3JD-22216-00	C-14	3XJ-23153-L0	D- 2
5X4-11922-00	B- 4	137-14143-64	B-10	1LX-15651-00	B-14	3XJ-21611-02	C- 9	3JD-22224-00	C-14		D- 3
3JE-11931-00	B- 4	137-14143-66-A1	B-10	1LX-15660-00	B-14	39X-21642-00	C- 9	3SP-22234-00	C-14	4V4-23153-L0	D- 2
3JE-11937-00	B- 2	137-14143-68	B-10	3XJ-16111-00	B-15	4DA-2165A-00	C- 9	3SP-22241-00	C-14		D- 3
5X4-11952-00	B- 4	137-14143-70	B-10	3XJ-16150-00	B-15	3XJ-21711-01	C-10	3XJ-22253-00	C-14	2HH-23158-L0	D- 2
3JD-11953-00	B- 4	3JD-14147-00	B- 9	3XJ-16164-00	B-15	3XJ-21717-00	C- 8	43M-22274-00	C-14		D- 3
3SR-11990-00	B- 4	3JE-14147-00	B- 9	3XJ-16181-00	B-15	3XJ-2172A-00	C-10	3XJ-22355-00	C-12	4DB-2316A-L0	D- 2
4DB-11992-00	B- 3	3JE-14171-00	B- 9	3XJ-16321-00	B-15	3XJ-2172F-00	C-11	3JD-22475-00	C-14		D- 3
4DB-11993-00	B- 3	3JD-14185-00	B- 9	3XJ-16324-00	B-15	2VM-2172K-00	C-10	3XJ-22475-00	C-13	4DB-2316A-M0	D- 2

NUMERICAL INDEX

PART NO.	GRID NO.	PART NO.	GRID NO.	PART NO.	GRID NO.	PART NO.	GRID NO.	PART NO.	GRID NO.	PART NO.	GRID NO.
4DB-2316A-M0	D- 3	1LX-24738-01	D- 6	3XJ-26111-00	D-12	90109-06577	E- 3	90201-06571	C- 9	90387-060A7	B-11
3XJ-23166-L0	D- 2	5X6-24748-10	D- 6	1LX-26241-01	D-12	90109-06799	E- 3	90201-06697	D- 5	90387-06027	D- 5
	D- 3	3XJ-24770-00	D- 6	1LX-26242-01	D-12	90109-08386	C- 7	90201-080E2	C- 7	90387-064W1	B- 7
4DA-23167-L0	D- 3	3XJ-24770-10	D- 6	23X-26243-00	D-12	90109-08792	D- 9	90201-08087	B- 2	90387-064X4	C-10
4DA-23170-L0	D- 2	4DA-25104-00	D- 7	5X2-2628H-01	D-12	90109-142F4	C-13	90201-081A6	C- 7		C-10
	D- 3	4DA-25111-00	D- 7	23X-26281-00	D-12	90116-08302	B- 2		C- 7	90387-074W0	B- 7
3XJ-23171-L0	D- 2	4DA-25181-00	D- 7	431-26282-02	D-12	90116-08388	B- 2		D- 9	90387-084X5	C-10
	D- 3	3JD-25304-00	D- 9	3JD-26311-01	D-12	90116-08394	B- 2	90201-084K3	C- 7		C-10
24M-23184-00	C-14	3SP-25311-00	D- 9	3XJ-26335-00	D-12	90116-08533	B- 2	90201-085E6	C- 7	90387-086N4	C- 7
4DA-2331E-L0	D- 4	3JD-25317-01	D- 9	56A-26372-01	D-13	90119-05193	C-10	90201-08512	B- 6	90387-087K5	C- 7
4DA-23340-L0	D- 3	4V4-25367-00	D-10	3JD-27200-01	D-14		C-10	90201-08612	B-11	90387-100Y1	B-11
3SP-23346-L0	D- 4	3JD-25381-01	D-10	4AA-27217-00	D-14		C-11	90201-08784	B- 6	90387-102W0	B- 2
3SP-23356-L0	D- 4	3SP-25388-00	D- 9	3SP-27222-00	D-15	90119-06063	C- 9	90201-10118	D-13	90387-103X9	C-13
4DA-23364-L0	E- 5	2X3-25394-00	D- 9	3SP-27311-00	D-14	90119-06185	B- 8		D-15	90387-152F2	B- 4
4DA-23389-00	C-15	5X2-25394-00	D- 7	4DA-27411-00	D-14		C- 9	90201-10119	B-15	90387-164N2	C-13
5Y3-23393-00	D- 3	39W-25444-01	D- 9	4DA-27421-00	D-14		C-15		D-14	90387-164N3	C-13
2HG-23416-00	C-15	39W-25445-01	D- 9	3JD-27491-00	D-11	90119-06192	C-10	90201-106F2	C-13	90387-167R5	C-13
3SP-23418-00	C-15	39W-25446-01	D- 9	56A-28166-00	C- 8		C-11	90201-10774	E- 2	90387-16781	B-12
4DB-23435-00	C-15	39W-25448-00	D- 9	3SR-82310-10	E- 4	90122-06030	B- 8	90201-12474	B-15	90387-172Y9	D- 7
3SP-23441-00	C-15	39W-25450-00	D- 9	2TV-82370-00	E- 4	90123-08090	D-12	90201-14740	C-13	90387-173Y0	D- 7
3SR-23442-00	C-15	3JD-25451-01	D- 9	1VJ-82519-00	E- 4	90149-06011	D- 5	90201-150H2	B-15	90387-200Y5	D- 9
4DA-23485-00	C-15	39P-25452-01	D- 9	4DB-82519-00	E- 4		E- 2	90201-154E9	B- 4	90387-202A0	C- 4
3XJ-23778-L0	D- 2	3SP-2580T-00	D- 8	1UA-82591-00	E- 4	90149-06153	E- 3	90201-15701	C- 3	90387-202T9	B-15
	D- 3	4DA-2580W-00	D-11	12R-82591-00	C- 7	90149-06272	D- 8	90201-164H4	C-12	90387-203V0	D- 9
4DA-23778-L0	D- 2	2VN-2582A-50	D-15		E- 4		D-11		C-13	90401-10034	D-13
	D- 3	4DA-2582T-00	D- 8		E- 4	90151-04048	C-12	90201-171G4	B-14		D-15
3XJ-24110-00	D- 5	4DA-2582W-00	D-11	38V-82911-00	E- 3	90157-06048	B-14	90201-204K8	B-15	90430-06014	B-15
5X6-2412F-00	D- 5	3SP-2583V-00	D-15	38V-82913-00	E- 3	90159-05122	C-15	90201-206K8	C- 3	90430-06016	B-13
24X-24144-00	D- 5	2VN-25852-00	D-13	23X-83912-00	E- 3	90159-06016	B-15	90201-22555	C- 3	90430-06166	B- 6
3SP-24173-00	D- 5	3XP-25852-50	D-15	3SP-83922-00	E- 3	90159-06056	D-15	90201-34683	C- 5	90430-12207	B-12
1LX-24181-00	D- 5	2VN-25854-00	D-15	25G-83936-01	E- 4	90159-06146	B-13	90201-365M5	C-15	90445-08605	B-12
22W-24181-00	C-10	56A-25854-00	D-13	437-83936-01	E- 3	90170-06010	E- 3	90202-05193	D- 5	90445-09058	D- 5
	C-10	2VN-25855-00	D-15	23X-83976-00	E- 3	90170-16326	B-15	90202-08022	C- 7	90445-09100	D- 5
3JD-24181-00	C-10	2VN-25866-00	D-15	4DB-85510-00	E- 2	90170-36394	C-15	90209-06096	B- 8	90445-11452	D- 5
4DB-24244-00	C-10	56A-25867-00	D-13	4DB-85540-00	E- 4	90176-08026	B- 2	90209-06290	B-12	90446-09013	B- 7
4DB-24245-00	C-11	3SP-25870-00	D-13	4DB-85546-00	E- 4	90179-08401	D-12	90209-18135	C- 3	90450-15041	B- 7
4DB-24249-02	C-11	4DA-25872-00	D-13	4DB-85550-00	E- 2	90179-08491	B- 2	90209-18208	C- 3	90450-17036	B- 7
4DB-24250-02	C-10	3SP-25873-00	D-15	4DB-85591-00	E- 4	90179-10544	C-13	90209-22257	B- 5	90450-22052	B- 7
3JD-24380-00	D- 5	2VM-25876-00	D-15	90101-06664	C- 6	90179-16226	C- 4		E- 6	90450-28014	B- 7
3XJ-24500-01	D- 5	3LC-25885-00	D-13	90101-08461	C- 7	90179-28602	C-15	90215-16245	B-15	90460-51109	B- 8
4X8-24512-00	D- 5		D-15	90101-08699	D- 9	90179-28603	C-15	90215-20261	C- 4	90460-68230	B- 8
3AJ-24534-00	D- 5	2VN-25894-00	D-15	90105-06553	C- 9	90185-14070	C-13	90240-08120	D-14	90462-12195	D-15
5X7-24611-01	D- 5	3JD-25895-00	D-15		E- 4	90185-16127	C-12	90240-10117	D-14	90464-14117	D-12
5X7-24612-00	D- 5	3JD-25919-00	D- 8	90105-08659	D- 8	90185-18104	D-10	90280-03017	B- 5	90465-08336	B-12
3L7-24724-00	D- 6	3SP-25919-51	D-11	90105-10445	B-15	90201-057H5	B- 4	90338-10150	C-12	90467-09006	B- 7
509-24724-00	D- 6	3XJ-25920-00	D-11	90105-10614	C-14	90201-06407	B-11	90340-12097	B-12	90467-10008	D- 5
3XJ-24731-00	D- 6	3SP-25924-51	D-11	90109-064F4	B-11	90201-065F3	B-14	90380-16056	C-12	90467-11044	D-15
3XJ-24731-10	D- 6	3GD-25933-00	D- 8	90109-06418	B-15	90201-06570	B- 7	90381-08002	B- 6	90468-26048	B-14

NUMERICAL INDEX

PART NO.	GRID NO.	PART NO.	GRID NO.	PART NO.	GRID NO.	PART NO.	GRID NO.	PART NO.	GRID NO.	PART NO.	GRID NO.
90480-15064	B- 7	92990-05100	B- 4	93315-22046	C-12	95021-08040	D- 4	97021-05030	B- 4		
90480-16233	B-11	92990-05200	C-10		C-12	95023-06008	B-11	97021-06012	B-14		
90480-18276	B- 7	92990-06100	B- 8	93315-31502	C- 2		B-13	97021-06016	E- 4		
90480-18549	D- 5		C-12	93317-22262	C-12		D-15	97780-50510	D-15		
90501-05265	C- 6		D- 3	93317-22263	C-12	95023-06010	B- 8	98501-04030	D- 4		
90501-06162	D-13		D- 5	93332-00067	C-15		B-11	98501-05012	B- 2		
90501-12081	B-14	92990-12200	C-15	93332-00068	C-15	95023-06012	B-11	98501-05016	C-10		
90501-23598	B-15	92990-18600	D-10	93340-21505	B- 4		D- 6	98501-06012	D- 6		
90501-240E7	B- 4	93102-15212	B-15		B-15	95023-06016	D- 5	98501-06030	B-13		
90506-14410	D-14	93102-17263	B-14	93342-22208	C-12	95023-06020	B- 7	98502-06016	B-13		
90507-20030	B-11	93102-22363	B- 5	93399-99935	C-13		B- 8	98503-03008	D- 5		
90508-14767	B-15	93102-22445	D- 7	93410-22039	C- 3		C-12	98506-05008	B- 2		
90508-14783	B- 4	93102-26042	C- 3		C- 3	95023-06025	B- 6	98506-05016	D-12		
90508-240A7	C- 5	93103-10147	B- 6	93440-15012	B-14		B-13	98511-04012	B- 9		
90508-26700	B-14	93103-32171	B- 5		C- 3	95023-06030	B- 7	98511-08010	B-12		
90508-28777	D-14	93104-08040	B- 4	93440-30113	C-13		B-13	98580-03008	B- 8		
90508-290A8	C- 6	93104-16074	B- 2	93450-17129	B- 5	95023-06035	B-13	98580-03010	B- 9		
90560-08213	B- 4	93106-22019	C-12		E- 6		D- 5	98580-05014	B- 3		
90560-12280	C- 6	93106-28023	D- 9	93507-32031	B-14	95023-06040	B-13	98701-06012	C- 3		
90560-17279	B-14	93108-35004	C-12	93521-64032	B- 4		B-13		C- 3		
90560-17379	D- 7	93109-12012	C- 6	93603-14179	B- 4	95023-08020	C-10	98701-06035	C-12		
90560-22281	D-12	93109-20029	C-12	93603-22028	B- 6		C-10	98706-04012	D-12		
91001-06020	C-12	93210-09192	B- 2	93604-08071	B- 2	95023-08030	B-11		D-13		
91021-06016	C-10	93210-14104	B-13	93604-10011	B- 6	95023-08035	C-15	98980-06020	D- 5		
91311-08025	D-11	93210-15151	B-14	93604-29184	B- 4	95023-08050	C-11	99009-10400	B-15		
91316-04006	B- 4	93210-15620	D-15	9383A-12017	C- 4	95026-06025	D-13	99080-07600	B- 6		
91316-05012	B-12	93210-27672	B- 2	9383A-13031	C- 4	95303-08600	D-15	99510-10114	B- 2		
91316-06035	B-12	93210-45742	B-11	9383A-14054	C- 4	95311-10600	E- 2	99510-12016	B-12		
91316-06045	B-12	93210-65721	B- 2	94108-217X6	D- 7	95601-05100	B- 8	99530-10014	B-13		
91316-06055	B-12	93211-07720	B- 2	94108-21905	D- 7	95601-08200	C- 7		B-13		
91316-06060	B-12	93300-60814	B- 4	94110-197X7	D- 9		C- 7				
91316-06065	B-12		B- 6	94110-19904	D- 9		C- 7				
91316-06070	B-12	93300-60816	C- 7	94209-21277	D- 7		C- 7				
91401-20015	D-14		C- 7	94210-19222	D- 9	95611-08100	D- 9				
91401-25020	C-15	93306-00316	D- 7	94210-19224	D- 9	95611-10200	C-14				
	D-14	93306-00418	D- 9	94227-21123	D- 7	95611-12100	C-15				
	D-14	93306-00438	D- 9	94307-21145	D- 7	95616-06100	E- 3				
92011-06012	D-11	93306-20431	C- 3	94316-19156	D- 9		E- 3				
92011-08070	C- 7	93306-30411	C- 3	94327-19111	D- 9	95701-08500	C-11				
	C- 7	93306-37204	B- 5	94330-21084	D- 7		D-10				
92013-06016	D-15	93310-216L2	B- 5	94416-21499	D- 7	95811-06012	C-10				
92901-06600	B-13		E- 6	94418-19485	D- 9	95811-08040	C- 7				
	D- 6	93310-225N0	B-15	94581-13116	D-10	95811-08055	C- 7				
92901-08200	C-10	93310-522M4	B- 5	94681-13001	D-10	95811-08095	C- 7				
92901-08600	D-14		E- 6	94702-00324	B- 2	95811-10016	C-13				
92902-04100	B- 9	93311-31567	C- 4	94709-00324	B- 2	97003-06012	D- 5				
92990-03100	B- 8	93311-41530	C- 3	95021-06060	B- 6	97006-05016	E- 3				
	B- 9	93315-10838	C- 2	95021-08040	C-15	97011-06025	C- 6				